

PHILIPPINE
PORTS
AUTHORITY



PHILIPPINE BIDDING DOCUMENTS

Procurement of GOODS

Government of the Republic of the Philippines

PMO AGS 002-2021

SUPPLY, DELIVERY, AND INSTALLATION OF MODULAR TABLES

**Sixth Edition
July 2020**

Table of Contents

Section I. Invitation to Bid.....	3
Section II. Instructions to Bidders.....	6
1. Scope of Bid	7
2. Funding Information.....	7
3. Bidding Requirements	7
4. Corrupt, Fraudulent, Collusive, and Coercive Practices.....	7
5. Eligible Bidders.....	7
6. Origin of Goods	8
7. Subcontracts	8
8. Pre-Bid Conference	9
9. Clarification and Amendment of Bidding Documents	9
10. Documents comprising the Bid: Eligibility and Technical Components	9
11. Documents comprising the Bid: Financial Component	9
12. Bid Prices	10
13. Bid and Payment Currencies	10
14. Bid Security	10
15. Sealing and Marking of Bids	11
16. Deadline for Submission of Bids	11
17. Opening and Preliminary Examination of Bids	11
18. Domestic Preference	11
19. Detailed Evaluation and Comparison of Bids	11
20. Post-Qualification	12
21. Signing of the Contract	12
Section III. Bid Data Sheet	13
Section IV. General Conditions of Contract	18
1. Scope of Contract	19
2. Advance Payment and Terms of Payment	19
3. Performance Security	19
4. Inspection and Tests	19
5. Warranty	20
6. Liability of the Supplier	20
Section V. Special Conditions of Contract	21
Section VI. Schedule of Requirements	26
Section VII. Technical Specifications	28
Section VIII. Checklist of Technical and Financial Documents	29

INVITATION TO BID FOR SUPPLY, DELIVERY, AND INSTALLATION OF MODULAR TABLES

1. The Philippine Ports Authority, Port Management of Agusan, through the corporate budget approved by the board for F.Y. 2021 intends to apply the sum of **Two Million Pesos (Php 2,000,000.00)** for the **Supply, Delivery, and Installation of Modular Tables per PMO AGS 002-2021** being the ABC to payments under the contract for the project, Bids received in excess of the ABC for each lot shall be automatically rejected at bid opening.
2. The Philippine Ports Authority, Port Management of Agusan now invites bids for the above Procurement Project. Delivery and Installation of the Goods is required within seventy-five (75) days upon the receipt of the Notice to Proceed. Bidders should have completed, within five (5) years from the date of submission and receipt of bids, a contract similar to the Project. The description of an eligible bidder is contained in the Bidding Documents, particularly, in Section II (Instructions to Bidders).
3. Bidding will be conducted through open competitive bidding procedures using a non-discretionary “*pass/fail*” criterion as specified in the 2016 revised Implementing Rules and Regulations (IRR) of Republic Act (RA) No. 9184.
 - a. Bidding is restricted to Filipino citizens/sole proprietorships, partnerships, or organizations with at least sixty percent (60%) interest or outstanding capital stock belonging to citizens of the Philippines, and to citizens or organizations of a country the laws or regulations of which grant similar rights or privileges to Filipino citizens, pursuant to RA No. 5183.
4. Prospective Bidders may obtain further information from Philippine Ports Authority, Port Management Office of Agusan and inspect the Bidding Documents at the address given below during office hours, **Monday to Friday 8:00 AM to 5:00 PM**.
5. A complete set of Bidding Documents may be acquired by interested Bidders starting on **September 8, 2021** from the given address and website(s) below and upon payment of the applicable fee for the Bidding Documents, pursuant to the latest Guidelines issued by the *GPPB*, in the amount of Five Thousand Pesos Only (Php 5,000.00). The Procuring Entity shall allow the bidder to present its proof of payment for the fees to be presented in person, or through electronic means.
6. The Philippine Ports Authority, Port Management Office of Agusan will hold a Pre-Bid Conference on **September 16, 2021, at 2:00 PM** at PPA-PMO Agusan Conference Room and through video conferencing, which shall be open to prospective bidders.
7. Bids must be duly received by the BAC Secretariat through manual submission at the office address indicated below, on or before **September 28, 2021, at 1:00 PM**. Late bids shall not be accepted.

8. All Bids must be accompanied by a bid security in any of the acceptable forms and in the amount stated in ITB Clause 14.
9. Bid opening shall be on **September 28, 2021, at 2:00 PM** at the given address below. Bids will be opened in the presence of the bidders' representatives who choose to attend the activity.
10. The Philippine Ports Authority, Port Management of Agusan reserves the right to reject any and all bids, declare a failure of bidding, or not award the contract at any time prior to contract award in accordance with Sections 35.6 and 41 of the 2016 revised IRR of RA No. 9184, without thereby incurring any liability to the affected bidder or bidders.
11. The Philippine Ports Authority, Port Management of Agusan reserves the right to reject any and all bids, declare a failure of bidding, or not award the contract at any time prior to contract award in accordance with Sections 35.6 and 41 of the 2016 revised IRR of RA No. 9184, without thereby incurring any liability to the affected bidder or bidders.
12. For further information, please refer to:

MR. GIDEON B. NACARIO

Procurement Officer B

Secretariat Head, Bids and Awards Committee

Philippine Ports Authority, Port Management of Agusan

Port Area, Talisay, Nasipit, Agusan del Norte

Tel. No. (085) 283-0200

Email Address: pmo_agusan@ppa.com.ph

13. You may visit the following websites:

For downloading of Bidding Documents: www.ppa.com.ph

JUANCHO I. TALLI
Division Manager A, Port Services Division
BAC Chairperson

1. Scope of Bid

The Procuring Entity, Philippine Ports Authority, Port management Office of Agusan wishes to receive Bids for the Supply, Deliver, and Installation of Modular Tables, with identification number PMO AGS 002-2021.

The Procurement Project (referred to herein as "Project") is composed of one (1) lot, the details of which are described in Section VII (Technical Specifications).

2. Funding Information

2.1. The GOP through the source of funding as indicated below for **2021** in the amount of **Two Million Pesos (Php 2,000,000.00)**.

2.2. The source of funding is:

GOCC and GFIs, the Corporate Operating Budget

3. Bidding Requirements

The Bidding for the Project shall be governed by all the provisions of RA No. 9184 and its 2016 revised IRR, including its Generic Procurement Manuals and associated policies, rules and regulations as the primary source thereof, while the herein clauses shall serve as the secondary source thereof.

Any amendments made to the IRR and other GPPB issuances shall be applicable only to the ongoing posting, advertisement, or **IB** by the BAC through the issuance of a supplemental or bid bulletin.

The Bidder, by the act of submitting its Bid, shall be deemed to have verified and accepted the general requirements of this Project, including other factors that may affect the cost, duration and execution or implementation of the contract, project, or work and examine all instructions, forms, terms, and project requirements in the Bidding Documents.

4. Corrupt, Fraudulent, Collusive, and Coercive Practices

The Procuring Entity, as well as the Bidders and Suppliers, shall observe the highest standard of ethics during the procurement and execution of the contract. They or through an agent shall not engage in corrupt, fraudulent, collusive, coercive, and obstructive practices defined under Annex "I" of the 2016 revised IRR of RA No. 9184 or other integrity violations in competing for the Project.

5. Eligible Bidders

5.1. Only Bids of Bidders found to be legally, technically, and financially capable will be evaluated.

- 5.2. Foreign ownership limited to those allowed under the rules may participate in this Project.
- 5.3. Pursuant to Section 23.4.1.3 of the 2016 revised IRR of RA No.9184, the Bidder shall have an SLCC that is at least one (1) contract similar to the Project the value of which, adjusted to current prices using the PSA's CPI, must be at least equivalent to:
 - a. For the procurement of Non-expendable Supplies and Services: The Bidder must have completed a single contract that is similar to this Project, equivalent to at least fifty percent (50%) of the ABC.
- 5.4. The Bidders shall comply with the eligibility criteria under Section 23.4.1 of the 2016 IRR of RA No. 9184.

6. Origin of Goods

There is no restriction on the origin of goods other than those prohibited by a decision of the UN Security Council taken under Chapter VII of the Charter of the UN, subject to Domestic Preference requirements under **ITB** Clause 18.

7. Subcontracts

- 7.1. The Bidder may subcontract portions of the Project to the extent allowed by the Procuring Entity as stated herein, but in no case more than twenty percent (20%) of the Project.

The Procuring Entity has prescribed that:

- a. Subcontracting is not allowed.
- 7.2. *[If Procuring Entity has determined that subcontracting is allowed during the bidding, state:]* The Bidder must submit together with its Bid the documentary requirements of the subcontractor(s) complying with the eligibility criteria stated in **ITB** Clause 5 in accordance with Section 23.4 of the 2016 revised IRR of RA No. 9184 pursuant to Section 23.1 thereof.
 - 7.3. *[If subcontracting is allowed during the contract implementation stage, state:]* The Supplier may identify its subcontractor during the contract implementation stage. Subcontractors identified during the bidding may be changed during the implementation of this Contract. Subcontractors must submit the documentary requirements under Section 23.1 of the 2016 revised IRR of RA No. 9184 and comply with the eligibility criteria specified in **ITB** Clause 5 to the implementing or end-user unit.
 - 7.4. Subcontracting of any portion of the Project does not relieve the Supplier of any liability or obligation under the Contract. The Supplier will be responsible for the acts, defaults, and negligence of any subcontractor, its agents, servants, or workmen as fully as if these were the Supplier's own acts, defaults, or negligence, or those of its agents, servants, or workmen.

8. Pre-Bid Conference

The Procuring Entity will hold a pre-bid conference for this Project on the specified date and time and either at its physical address Port Area, Talisay, Nasipit, Agusan del Norte and through videoconferencing as indicated in paragraph 6 of the **IB**.

9. Clarification and Amendment of Bidding Documents

Prospective bidders may request for clarification on and/or interpretation of any part of the Bidding Documents. Such requests must be in writing and received by the Procuring Entity, either at its given address or through electronic mail indicated in the **IB**, at least ten (10) calendar days before the deadline set for the submission and receipt of Bids.

10. Documents comprising the Bid: Eligibility and Technical Components

- 10.1. The first envelope shall contain the eligibility and technical documents of the Bid as specified in **Section VIII (Checklist of Technical and Financial Documents)**.
- 10.2. The Bidder's SLCC as indicated in **ITB** Clause 5.3 should have been completed within five (5) years prior to the deadline for the submission and receipt of bids.
- 10.3. If the eligibility requirements or statements, the bids, and all other documents for submission to the BAC are in foreign language other than English, it must be accompanied by a translation in English, which shall be authenticated by the appropriate Philippine foreign service establishment, post, or the equivalent office having jurisdiction over the foreign bidder's affairs in the Philippines. Similar to the required authentication above, for Contracting Parties to the Apostille Convention, only the translated documents shall be authenticated through an apostille pursuant to GPPB Resolution No. 13-2019 dated 23 May 2019. The English translation shall govern, for purposes of interpretation of the bid.

11. Documents comprising the Bid: Financial Component

- 11.1. The second bid envelope shall contain the financial documents for the Bid as specified in **Section VIII (Checklist of Technical and Financial Documents)**.
- 11.2. If the Bidder claims preference as a Domestic Bidder or Domestic Entity, a certification issued by DTI shall be provided by the Bidder in accordance with Section 43.1.3 of the 2016 revised IRR of RA No. 9184.
- 11.3. Any bid exceeding the ABC indicated in paragraph 1 of the **IB** shall not be accepted.
- 11.4. For Foreign-funded Procurement, a ceiling may be applied to bid prices provided the conditions are met under Section 31.2 of the 2016 revised IRR of RA No. 9184.

12. Bid Prices

12.1. Prices indicated on the Price Schedule shall be entered separately in the following manner:

- a. For Goods offered from within the Procuring Entity's country:
 - i. The price of the Goods quoted EXW (ex-works, ex-factory, ex-warehouse, ex-showroom, or off-the-shelf, as applicable);
 - ii. The cost of all customs duties and sales and other taxes already paid or payable;
 - iii. The cost of transportation, insurance, and other costs incidental to delivery of the Goods to their final destination; and
 - iv. The price of other (incidental) services, if any, listed in the **BDS**.
- b. For Goods offered from abroad:
 - i. Unless otherwise stated in the **BDS**, the price of the Goods shall be quoted delivered duty paid (DDP) with the place of destination in the Philippines as specified in the **BDS**. In quoting the price, the Bidder shall be free to use transportation through carriers registered in any eligible country. Similarly, the Bidder may obtain insurance services from any eligible source country.
 - ii. The price of other (incidental) services, if any, as listed in the **BDS**.

13. Bid and Payment Currencies

13.1. For Goods that the Bidder will supply from outside the Philippines, the bid prices may be quoted in the local currency or tradeable currency accepted by the BSP at the discretion of the Bidder. However, for purposes of bid evaluation, Bids denominated in foreign currencies, shall be converted to Philippine currency based on the exchange rate as published in the BSP reference rate bulletin on the day of the bid opening.

13.2. Payment of the contract price shall be made in:

- a. Philippine Pesos.

14. Bid Security

14.1. The Bidder shall submit a Bid Securing Declaration or any form of Bid Security in the amount indicated in the **BDS**, which shall be not less than the percentage of the ABC in accordance with the schedule in the **BDS**.

14.2. The Bid and bid security shall be valid until **120 calendar** days from the date of opening of bids. Any Bid not accompanied by an acceptable bid security shall be rejected by the Procuring Entity as non-responsive.

15. Sealing and Marking of Bids

Each Bidder shall submit one copy of the first and second components of its Bid.

The Procuring Entity may request additional hard copies and/or electronic copies of the Bid. However, failure of the Bidders to comply with the said request shall not be a ground for disqualification.

If the Procuring Entity allows the submission of bids through online submission or any other electronic means, the Bidder shall submit an electronic copy of its Bid, which must be digitally signed. An electronic copy that cannot be opened or is corrupted shall be considered non-responsive and, thus, automatically disqualified.

16. Deadline for Submission of Bids

16.1. The Bidders shall submit on the specified date and time and either at its physical address or through online submission as indicated in paragraph 7 of the **IB**.

17. Opening and Preliminary Examination of Bids

17.1. The BAC shall open the Bids in public at the time, on the date, and at the place specified in paragraph 9 of the **IB**. The Bidders' representatives who are present shall sign a register evidencing their attendance. In case videoconferencing, webcasting or other similar technologies will be used, attendance of participants shall likewise be recorded by the BAC Secretariat.

In case the Bids cannot be opened as scheduled due to justifiable reasons, the rescheduling requirements under Section 29 of the 2016 revised IRR of RA No. 9184 shall prevail.

17.2. The preliminary examination of bids shall be governed by Section 30 of the 2016 revised IRR of RA No. 9184.

18. Domestic Preference

18.1. The Procuring Entity will grant a margin of preference for the purpose of comparison of Bids in accordance with Section 43.1.2 of the 2016 revised IRR of RA No. 9184.

19. Detailed Evaluation and Comparison of Bids

19.1. The Procuring Entity's BAC shall immediately conduct a detailed evaluation of all Bids rated "*passed*," using non-discretionary pass/fail criteria. The BAC shall consider the conditions in the evaluation of Bids under Section 32.2 of the 2016 revised IRR of RA No. 9184.

19.2. If the Project allows partial bids, bidders may submit a proposal on any of the lots or items, and evaluation will be undertaken on a per lot or item basis, as the case maybe. In this case, the Bid Security as required by **ITB** Clause 14 shall be submitted for each lot or item separately.

19.3. The descriptions of the lots or items shall be indicated in **Section VII (Technical Specifications)**, although the ABCs of these lots or items are indicated in the **BDS** for purposes of the NFCC computation pursuant to Section 23.4.2.6 of the 2016 revised IRR of RA No. 9184. The NFCC must be sufficient for the total of the ABCs for all the lots or items participated in by the prospective Bidder.

19.4. The Project shall be awarded as follows:

Option 1 – One Project having several items that shall be awarded as one contract.

19.5. Except for bidders submitting a committed Line of Credit from a Universal or Commercial Bank in lieu of its NFCC computation, all Bids must include the NFCC computation pursuant to Section 23.4.1.4 of the 2016 revised IRR of RA No. 9184, which must be sufficient for the total of the ABCs for all the lots or items participated in by the prospective Bidder. For bidders submitting the committed Line of Credit, it must be at least equal to ten percent (10%) of the ABCs for all the lots or items participated in by the prospective Bidder.

20. Post-Qualification

20.1. Within a non-extendible period of five (5) calendar days from receipt by the Bidder of the notice from the BAC that it submitted the Lowest Calculated Bid, the Bidder shall submit its latest income and business tax returns filed and paid through the BIR Electronic Filing and Payment System (eFPS) and other appropriate licenses and permits required by law and stated in the **BDS**.

21. Signing of the Contract

21.1. The documents required in Section 37.2 of the 2016 revised IRR of RA No. 9184 shall form part of the Contract. Additional Contract documents are indicated in the **BDS**.

Bid Data Sheet

ITB Clause	
5.3	<p>For this purpose, contracts similar to the Project shall be:</p> <ul style="list-style-type: none"> a. Any contract on Supply, Delivery, and Installation of Modular Tables and must be at least equivalent to fifty percent (50%) of the ABC of bidded project; and b. completed within five (5) years prior to the deadline for the submission and receipt of bids.
7.1	The Procuring Entity has prescribed that subcontracting is not allowed .
12	The price of the Goods shall be quoted DDP in the or the applicable International Commercial Terms (INCOTERMS) for this Project.
14.1	<p>The bid security shall be in the form of a Bid Securing Declaration, or any of the following forms and amounts:</p> <ul style="list-style-type: none"> a. The amount of not less than Forty Thousand Pesos (Php 40,000.00), if bid security is in cash, cashier's/manager's check, bank draft/guarantee or irrevocable letter of credit; or b. The amount of not less than One Hundred Thousand Pesos (Php 100,000.00) if bid security is in Surety Bond.
15	<p>Each Bidder shall submit one (1) original and five (5) copies of the first and second components of its bid.</p> <p>The duplicates: all copies must include the same documents as that of the original set of documents</p>
19.3	<p>The NFCC computation, if applicable, must be sufficient for the contract to be awarded to the Bidder:</p> <p>Lot No.: 1</p> <p>Item/Description: Supply, Delivery, and Installation of Modular Tables (Please refer to Terms of Reference for Technical Specifications and Drawings)</p> <p>ABC: Two Million Pesos Only (Php 2,000,000.00)</p>
20.2	<p>For purposes of Post-qualification the following document(s) shall be required:</p> <ul style="list-style-type: none"> 1. Latest Annual Income Tax Returns (BIR Form 1701 or 1702). 2. Value Added Tax Returns (Forms 2550M and 2550Q) or Percentage Tax Returns (Form 2551M) covering the previous six (6) months.

The income tax and business tax returns stated above should have been filed through the Electronic Filing and Payment System (EFPS).

3. Pursuant to BIR Revenue Regulations No. 03-2005 dated 16 February 2005.
4. Proof of completion of the single largest contract as identified in the Statement of Single Largest Contract, which shall be copy of any verifiable document(s) such as but not limited to the following:
 - (a) Contract/s or Purchase Order/s;
 - (b) Corresponding Sales Invoice/s;
 - (c) Official Receipt/Cash Receipt/Collection Receipt; and
 - (d) Certificate of Satisfactory Completion.

NOTE: The requirement on SLCC is not applicable for bidders with DTI Certificate of Domestic Preference (DoBid).

4. Submission of proof of evidence as proof of compliance with the bidder's actual offer, if applicable.

In the column "Bidder's Compliance", the bidder must state "comply" against each of the individual parameters of each specification corresponding to performance parameter of equipment offered. Statement of "comply" must be supported by evidence in a bidder's bid and cross-referenced to that evidence. Evidence shall be in the form of manufacturer's or distributor's un-amended sales literature, unconditional statements or specification and compliance issued by the manufacturer or distributor, samples, independent test data etc., as appropriate.

5. Valid and updated PhilGEPS Certificate of Registration (Platinum Membership), in the event that the PhilGEPS Certificate and the annexes submitted during Opening of Bids is not updated.

N.B. Documents submitted during post-qualification as part of post-qualification documents must be certified by the authorized representative to be true copy of the original.

6. The veracity of the subscribed Omnibus Sworn Statement submitted in accordance with Sec. 25.3 of the 2016 IRR of RA 9184 may be subject to verification. If found to be non-compliant, this shall serve as ground for post-disqualification as specified in GPPB Circular No. 01 - 2008 dated 7 March 2008.

7. To determine the compliance of the items with the requirements of the agency, the actual sample of each item being offered by the bidder together with the Technical Data Sheet will be submitted for purposes of post-qualification. The bidder will have one (1) chance to present such items.

8. If the bidder fails to present the sample of the items being offered by them during the scheduled date of presentation, the Bids and Awards Committee (BAC) will declare the bidder post-disqualified for failure to comply with the

	<p>requirements. The bidder will also be considered post-disqualified if different samples are presented for the same item.</p> <p>9. For common items found in same or different lots but with different purpose, the bidders may present one (1) sample for all the lots.</p> <p>For this purpose, the term "common items" excludes items which have the same description but with different technical specification.</p> <p>10. Imported products (for electronic products) should pass international quality control product standards and have international quality control product markings such as CE, ISO, ASTM, ASQC, AFCIQ, ASQ, DGQ, EOQC, IQA, and the like.</p> <p>11. For local manufacturers:</p> <ul style="list-style-type: none"> (a) Valid and current Certificate of Product Registration (CPR); (b) Valid and current License to Operate (LTO); (c) Certificate of Preference for Domestic Bidders Participating in Government Procurement Projects issued by the DTI, if available; and (d) Other relevant ISO or any international technical standard compliance certification, if applicable. <p>For imported goods:</p> <ul style="list-style-type: none"> (a) Marketing authorization, registration approval, or free sale certificate of the product issued in the country of origin; (b) Authentication or red ribbon certificate from Philippine consulate/embassy or documents authenticated through an Apostille by the Competent Authority based on the Apostille Convention. <p>12. Proof of availability of stocks such as but not limited to:</p> <ul style="list-style-type: none"> - Photos/Videos of the items in the supplier's warehouse - Import Documents or other related documents
21.2	No further instructions

SEALING AND MARKING OF BIDS

(Two – Envelope System)

Envelope 1 original
TECHNICAL
COMPONENT
(Eligibility and Technical Document)

Envelope 1 Copies 1 - 5
TECHNICAL
COMPONENT
(Eligibility and Technical Document)

Envelope 2 original
FINANCIAL
COMPONENT

Envelope 2 Copies 1 - 5
FINANCIAL
COMPONENT

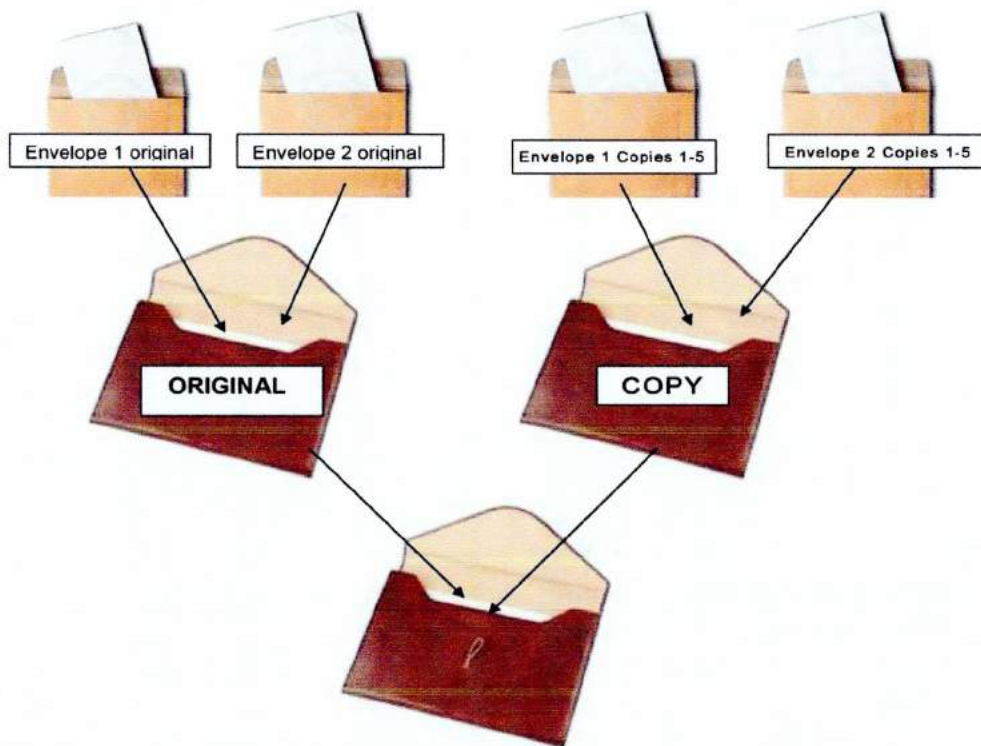

Section IV. General Conditions of Contract

1. Scope of Contract

This Contract shall include all such items, although not specifically mentioned, that can be reasonably inferred as being required for its completion as if such items were expressly mentioned herein. All the provisions of RA No. 9184 and its 2016 revised IRR, including the Generic Procurement Manual, and associated issuances, constitute the primary source for the terms and conditions of the Contract, and thus, applicable in contract implementation. Herein clauses shall serve as the secondary source for the terms and conditions of the Contract.

This is without prejudice to Sections 74.1 and 74.2 of the 2016 revised IRR of RA No. 9184 allowing the GPPB to amend the IRR, which shall be applied to all procurement activities, the advertisement, posting, or invitation of which were issued after the effectivity of the said amendment.

Additional requirements for the completion of this Contract shall be provided in the **Special Conditions of Contract (SCC)**.

2. Advance Payment and Terms of Payment

2.1. Advance payment of the contract amount is provided under Annex "D" of the revised 2016 IRR of RA No. 9184.

2.2. The Procuring Entity is allowed to determine the terms of payment on the partial or staggered delivery of the Goods procured, provided such partial payment shall correspond to the value of the goods delivered and accepted in accordance with prevailing accounting and auditing rules and regulations. The terms of payment are indicated in the SCC.

3. Performance Security

Within ten (10) calendar days from receipt of the Notice of Award by the Bidder from the Procuring Entity but in no case later than the signing of the Contract by both parties, the successful Bidder shall furnish the performance security in any of the forms prescribed in Section 39 of the 2016 revised IRR of RA No. 9184.

4. Inspection and Tests

The Procuring Entity or its representative shall have the right to inspect and/or to test the Goods to confirm their conformity to the Project specifications at no extra cost to the Procuring Entity in accordance with the Generic Procurement Manual. In addition to tests in the SCC, **Section VII (Technical Specifications)** shall specify what inspections and/or tests the Procuring Entity requires, and where they are to be conducted. The Procuring Entity shall notify the Supplier in writing, in a timely manner, of the identity of any representatives retained for these purposes.

All reasonable facilities and assistance for the inspection and testing of Goods, including access to drawings and production data, shall be provided by the Supplier to the authorized inspectors at no charge to the Procuring Entity.

5. Warranty

- 5.1 In order to assure that manufacturing defects shall be corrected by the Supplier, a warranty shall be required from the Supplier as provided under Section 62.1 of the 2016 revised IRR of RA No. 9184.
- 5.2 The Procuring Entity shall promptly notify the Supplier in writing of any claims arising under this warranty. Upon receipt of such notice, the Supplier shall, repair or replace the defective Goods or parts thereof without cost to the Procuring Entity, pursuant to the Generic Procurement Manual.

6. Liability of the Supplier

The Supplier's liability under this Contract shall be as provided by the laws of the Republic of the Philippines.

If the Supplier is a joint venture, all partners to the joint venture shall be jointly and severally liable to the Procuring Entity.

Section V. Special Conditions of Contract

Special Conditions of Contract

GCC Clause	
1	<p>This project covers the selected buildings in Port Management Office of Agusan</p> <ul style="list-style-type: none"> • Port Operations Building, Talisay, Nasipit, Agusan del Norte • Port Integrated Clearing Office, Talisay, Nasipit Agusan del Norte • Port Police Building, Talisay, Nasipit, Agusan del Norte <p>Delivery and Documents –</p> <p>For purposes of the Contract, “EXW,” “FOB,” “FCA,” “CIF,” “CIP,” “DDP” and other trade terms used to describe the obligations of the parties shall have the meanings assigned to them by the current edition of INCOTERMS published by the International Chamber of Commerce, Paris. The Delivery terms of this Contract shall be as follows:</p> <p><i>[For Goods supplied from abroad, state:]</i> “The delivery terms applicable to the Contract are DDP delivered <i>[indicate place of destination]</i>. In accordance with INCOTERMS.”</p> <p><i>[For Goods supplied from within the Philippines, state:]</i> “The delivery terms applicable to this Contract are delivered <i>[indicate place of destination]</i>. Risk and title will pass from the Supplier to the Procuring Entity upon receipt and final acceptance of the Goods at their final destination.”</p> <p>Delivery of the Goods shall be made by the Supplier in accordance with the terms specified in Section VI (Schedule of Requirements).</p> <p>For purposes of this Clause the Procuring Entity’s Representative is <i>Ms. Anna Grace P. Gual</i></p> <p>Incidental Services –</p> <p>The Supplier is required to provide all of the following services, including additional services, if any, specified in Section VI. Schedule of Requirements:</p> <ol style="list-style-type: none"> a. Supply, Delivery, and Installation b. performance or supervision of on-site assembly and/or start-up of the supplied Goods; c. performance or supervision or maintenance and/or repair of the supplied Goods, for a period of time agreed by the parties, provided that this service shall not relieve the Supplier of any warranty obligations under this Contract; and

The Contract price for the Goods shall include the prices charged by the Supplier for incidental services and shall not exceed the prevailing rates charged to other parties by the Supplier for similar services.

Spare Parts –

The Supplier is required to provide all of the following materials, notifications, and information pertaining to spare parts manufactured or distributed by the Supplier:

1. such spare parts as the Procuring Entity may elect to purchase from the Supplier, provided that this election shall not relieve the Supplier of any warranty obligations under this Contract; and
2. in the event of termination of production of the spare parts:
 - i. advance notification to the Procuring Entity of the pending termination, in sufficient time to permit the Procuring Entity to procure needed requirements; and
 - ii. following such termination, furnishing at no cost to the Procuring Entity, the blueprints, drawings, and specifications of the spare parts, if requested.

The spare parts and other components required are listed in **Section VI (Schedule of Requirements)** and the costs thereof are included in the contract price.

The Supplier shall carry sufficient inventories to assure ex-stock supply of consumable spare parts or components for the Goods for a period of twelve (12) months

Spare parts or components shall be supplied as promptly as possible, but in any case, within one (1) months of placing the order.

Packaging –

The Supplier shall provide such packaging of the Goods as is required to prevent their damage or deterioration during transit to their final destination, as indicated in this Contract. The packaging shall be sufficient to withstand, without limitation, rough handling during transit and exposure to extreme temperatures, salt and precipitation during transit, and open storage. Packaging case size and weights shall take into consideration, where appropriate, the remoteness of the Goods' final destination and the absence of heavy handling facilities at all points in transit.

	<p>The packaging, marking, and documentation within and outside the packages shall comply strictly with such special requirements as shall be expressly provided for in the Contract, including additional requirements, if any, specified below, and in any subsequent instructions ordered by the Procuring Entity.</p> <p>The outer packaging must be clearly marked on at least four (4) sides as follows:</p> <p>Name of the Procuring Entity Name of the Supplier Contract Description Final Destination Gross weight Any special lifting instructions Any special handling instructions Any relevant HAZCHEM classifications</p>
	<p>A packaging list identifying the contents and quantities of the package is to be placed on an accessible point of the outer packaging if practical. If not practical the packaging list is to be placed inside the outer packaging but outside the secondary packaging.</p> <p>Transportation –</p> <p>Where the Supplier is required under Contract to deliver the Goods CIF, CIP, or DDP, transport of the Goods to the port of destination or such other named place of destination in the Philippines, as shall be specified in this Contract, shall be arranged and paid for by the Supplier, and the cost thereof shall be included in the Contract Price.</p> <p>Where the Supplier is required under this Contract to transport the Goods to a specified place of destination within the Philippines, defined as the Project Site, transport to such place of destination in the Philippines, including insurance and storage, as shall be specified in this Contract, shall be arranged by the Supplier, and related costs shall be included in the contract price.</p>
	<p>Where the Supplier is required under Contract to deliver the Goods CIF, CIP or DDP, Goods are to be transported on carriers of Philippine registry. In the event that no carrier of Philippine registry is available, Goods may be shipped by a carrier which is not of Philippine registry provided that the Supplier obtains and presents to the Procuring Entity certification to this effect from the nearest Philippine consulate to the port of dispatch. In the event that carriers of Philippine registry are available but their schedule delays the Supplier in its performance of this Contract the period from when the Goods were first ready for shipment and the actual date of shipment the period of delay will be considered force majeure.</p> <p>The Procuring Entity accepts no liability for the damage of Goods during transit other than those prescribed by INCOTERMS for DDP deliveries. In the case of Goods supplied from within the Philippines or supplied by domestic</p>

	<p>Suppliers risk and title will not be deemed to have passed to the Procuring Entity until their receipt and final acceptance at the final destination.</p> <p>Intellectual Property Rights –</p> <p>The Supplier shall indemnify the Procuring Entity against all third-party claims of infringement of patent, trademark, or industrial design rights arising from use of the Goods or any part thereof.</p>
2.2	The procuring entity does not allow partial payment on this project. Full payment shall be done within thirty (30) days upon the inspection and acceptance of the said project.
4	N/A
5.1	A warranty retention equivalent to at least 1% shall be required for one (1) year after End-User's acceptance.

Section VI. Schedule of Requirements

The delivery and installation schedule expressed as weeks/months stipulates hereafter a delivery date which is the date of delivery to the project site.

Item Number	Description	QTY	Total	Delivered, Weeks/Months
	Supply, Delivery and Installation of Modular Tables	1	Php 2,000,000.00	Within seventy-five (75) days upon the receipt of the Notice to Proceed
1	Sr. Modular Table (L Type with Mobile Pedestal) Dimension: W1700 x D1700 x H1500 Material: High Moisture (HMR) Resistant Particle Board with Acrylic Glass Partition)	15		
2	Jr. Modular Table (L Type with Mobile Pedestal) Dimension: W1500 x D1500 x H1500 Material: High Moisture (HMR) Resistant Particle Board with Acrylic Glass Partition)	40		

I hereby commit to comply and deliver all the above requirements in accordance with the above stated schedule.

Name of Company

Signature Over Printed Name
Name of Authorized Representative

Date

Section VII. Technical Specifications

Technical Specifications

Item	Specification	Statement of Compliance
1	Sr. Modular Table (L Type with Mobile Pedestal) Dimension: W1700 x D1700 x H1500 Material: High Moisture (HMR) Resistant Particle Board with Acrylic Glass Partition)	
2	Jr. Modular Table (L Type with Mobile Pedestal) Dimension: W1500 x D1500 x H1500 Material: High Moisture (HMR) Resistant Particle Board with Acrylic Glass Partition)	

I hereby certify that the statement of compliance to the foregoing technical specifications are true and correct, and that the items to be delivered shall be consistent with such and the sample submitted; otherwise, if found to be false either during bid evaluation or post-qualification, the same shall give rise to automatic disqualification of our bid.

Name of Company

Signature Over Printed Name
Name of Authorized Representative

Date

***Section VIII. Checklist of Technical and
Financial Documents***

Checklist of Technical and Financial Documents

I. TECHNICAL COMPONENT ENVELOPE

Class "A" Documents

Legal Documents

- (a) Valid PhilGEPS Registration Certificate (Platinum Membership) (all pages);
or
- (b) Registration certificate from Securities and Exchange Commission (SEC), Department of Trade and Industry (DTI) for sole proprietorship, or Cooperative Development Authority (CDA) for cooperatives or its equivalent document,
and
- (c) Mayor's or Business permit issued by the city or municipality where the principal place of business of the prospective bidder is located, or the equivalent document for Exclusive Economic Zones or Areas;
and
- (d) Tax clearance per E.O. No. 398, s. 2005, as finally reviewed and approved by the Bureau of Internal Revenue (BIR).

Technical Documents

- (e) Statement of the prospective bidder of all its ongoing government and private contracts, including contracts awarded but not yet started, if any, whether similar or not similar in nature and complexity to the contract to be bid; **and**
- (f) Statement of the bidder's Single Largest Completed Contract (SLCC) similar to the contract to be bid, except under conditions provided for in Sections 23.4.1.3 and 23.4.2.4 of the 2016 revised IRR of RA No. 9184, within the relevant period as provided in the Bidding Documents; **and**
- (g) Original copy of Bid Security. If in the form of a Surety Bond, submit also a certification issued by the Insurance Commission;
or
Original copy of Notarized Bid Securing Declaration; **and**
- (h) Conformity with the Technical Specifications, which may include production/delivery schedule, manpower requirements, and/or after-sales/parts, if applicable; **and**
- (i) Original duly signed Omnibus Sworn Statement (OSS);
and if applicable, Original Notarized Secretary's Certificate in case of a corporation, partnership, or cooperative; or Original Special Power of Attorney of all members of the joint venture giving full power and authority to its officer to sign the OSS and do acts to represent the Bidder.

Financial Documents

- (j) The Supplier's audited financial statements, showing, among others, the Supplier's total and current assets and liabilities, stamped "received" by the BIR or its duly accredited and authorized institutions, for the preceding calendar year which should not be earlier than two (2) years from the date of bid submission; **and**
- (k) The prospective bidder's computation of Net Financial Contracting Capacity (NFCC);

or

A committed Line of Credit from a Universal or Commercial Bank in lieu of its NFCC computation.

Class "B" Documents

- (l) If applicable, a duly signed joint venture agreement (JVA) in case the joint venture is already in existence;
- or**
duly notarized statements from all the potential joint venture partners stating that they will enter into and abide by the provisions of the JVA in the instance that the bid is successful.

II. FINANCIAL COMPONENT ENVELOPE

- (m) Original of duly signed and accomplished Financial Bid Form; **and**
- (n) Original of duly signed and accomplished Price Schedule(s).

Other documentary requirements under RA No. 9184 (as applicable)

- (o) *[For foreign bidders claiming by reason of their country's extension of reciprocal rights to Filipinos]* Certification from the relevant government office of their country stating that Filipinos are allowed to participate in government procurement activities for the same item or product.
- (p) Certification from the DTI if the Bidder claims preference as a Domestic Bidder or Domestic Entity.

To: Philippine Ports Authority
Port Management Office of Agusan
Port Area, Talisay, Nasipit
Agusan del Norte

We, the undersigned, declare that :

(a) We have examined and have no reservation to the Bidding Documents, Including Addenda, for the Supply, Delivery, and Installation of Modular Tables for PPA-PMO Agusan.

(b) We offer to execute the Works for this Contract in accordance with Bid and Bid Data Sheet, general and Special Conditions of Contract accompanying this Bid;

The total price of our Bid, excluding any discount offered in item (d) below is :

Bill Number	Description	Total Amount
1 lot	Supply, Delivery and Installation of Modular Tables	

The Discounts offered and the methodology for their application are :

Delivery / Installation Period: 75 Calendar Days after Receipt of Notice to Proceed

(c) Our Bid shall be valid for a period of 75 days from the date fixed for the Bid Submission deadline in accordance with the Bidding Documents, and it shall remain binding upon us and may be accepted at any time before the expiration of that period.

(d) If our Bid is accepted, we commit to obtain a Performance Security in the form of Surety Bond and in the amount equivalent to 5% of the Contract Price for the due performance of the contract.

(e) Our firm, including any subcontractors or suppliers for any part of the contract, have Nationalities from the following eligible countries: (Insert Information)

(f) We are not participating, as Bidders, in more than one Bid in this bidding process, other than alternative offers in accordance with the Bidding Documents.

(g) Our firm, its affiliates or subsidiaries, including any subcontractors or suppliers for any part of the contract, has not been declared ineligible by the Funding Source.

(h) We understand that this Bid, together with your written acceptance thereof included in your Notification of Award, shall constitute a binding contract between us, until a formal Purchase Order is prepared and executed.

Name: _____

In Capacity of: _____

Signed: _____

Duly authorized to sign the bid on behalf: _____

Date: _____

Bid Form for the Procurement of Goods
[shall be submitted with the Bid]

BID FORM

Date : _____
 Project Identification No. : _____

To: *[name and address of Procuring Entity]*

Having examined the Philippine Bidding Documents (PBDs) including the Supplemental or Bid Bulletin Numbers *[insert numbers]*, the receipt of which is hereby duly acknowledged, we, the undersigned, offer to *[supply/deliver/perform]* *[description of the Goods]* in conformity with the said PBDs for the sum of *[total Bid amount in words and figures]* or the total calculated bid price, as evaluated and corrected for computational errors, and other bid modifications in accordance with the Price Schedules attached herewith and made part of this Bid. The total bid price includes the cost of all taxes, such as, but not limited to: *[specify the applicable taxes, e.g. (i) value added tax (VAT), (ii) income tax, (iii) local taxes, and (iv) other fiscal levies and duties]*, which are itemized herein or in the Price Schedules,

If our Bid is accepted, we undertake:

- a. to deliver the goods in accordance with the delivery schedule specified in the Schedule of Requirements of the Philippine Bidding Documents (PBDs);
- b. to provide a performance security in the form, amounts, and within the times prescribed in the PBDs;
- c. to abide by the Bid Validity Period specified in the PBDs and it shall remain binding upon us at any time before the expiration of that period.

[Insert this paragraph if Foreign-Assisted Project with the Development Partner:

Commissions or gratuities, if any, paid or to be paid by us to agents relating to this Bid, and to contract execution if we are awarded the contract, are listed below:

Name and address of agent	Amount and Purpose of Commission or gratuity
---------------------------	--

(if none, state "None")]

Until a formal Contract is prepared and executed, this Bid, together with your written acceptance thereof and your Notice of Award, shall be binding upon us.

We understand that you are not bound to accept the Lowest Calculated Bid or any Bid you may receive.

We certify/confirm that we comply with the eligibility requirements pursuant to the PBDs.

The undersigned is authorized to submit the bid on behalf of *[name of the bidder]* as evidenced by the attached *[state the written authority]*.

We acknowledge that failure to sign each and every page of this Bid Form, including the attached Schedule of Prices, shall be a ground for the rejection of our bid.

Name: _____

Legal capacity: _____

Signature: _____

Duly authorized to sign the Bid for and behalf of: _____

Date: _____

Price Schedule for Goods Offered from Abroad

[shall be submitted with the Bid if bidder is offering goods from Abroad]

For Goods Offered from Abroad

Name of Bidder _____ Project ID No. _____ Page ___ of ___

1	2	3	4	5	6	7	8	9
Item	Description	Country of origin	Quantity	Unit price CIF port of entry (specify port) or CIP named place (specify border point or place of destination)	Total CIF or CIP price per item (col. 4 x 5)	Unit Price Delivered Duty Unpaid (DDU)	Unit price Delivered Duty Paid (DDP)	Total Price delivered DDP (col 4 x 8)

Name: _____

Legal Capacity: _____

Signature: _____

Duly authorized to sign the Bid for and behalf of: _____

Price Schedule for Goods Offered from Within the Philippines
[shall be submitted with the Bid if bidder is offering goods from within the Philippines]

For Goods Offered from Within the Philippines

Name of Bidder _____ Project ID No. _____ Page ___ of ___

1	2	3	4	5	6	7	8	9	10
Item	Description	Country of origin	Quantity	Unit price EXW per item	Transportation and all other costs incidental to delivery, per item	Sales and other taxes payable if Contract is awarded, per item	Cost of Incidental Services, if applicable, per item	Total Price, per unit (col 5+6+7+8)	Total Price delivered Final Destination (col 9) x (col 4)

Name: _____

Legal Capacity: _____

Signature: _____

Duly authorized to sign the Bid for and behalf of: _____

Omnibus Sworn Statement (Revised)
[shall be submitted with the Bid]

REPUBLIC OF THE PHILIPPINES)
CITY/MUNICIPALITY OF _____) S.S.

AFFIDAVIT

I, [Name of Affiant], of legal age, [Civil Status], [Nationality], and residing at [Address of Affiant], after having been duly sworn in accordance with law, do hereby depose and state that:

1. *[Select one, delete the other:]*

[If a sole proprietorship:] I am the sole proprietor or authorized representative of [Name of Bidder] with office address at [address of Bidder];

[If a partnership, corporation, cooperative, or joint venture:] I am the duly authorized and designated representative of [Name of Bidder] with office address at [address of Bidder];

2. *[Select one, delete the other:]*

[If a sole proprietorship:] As the owner and sole proprietor, or authorized representative of [Name of Bidder], I have full power and authority to do, execute and perform any and all acts necessary to participate, submit the bid, and to sign and execute the ensuing contract for [Name of the Project] of the [Name of the Procuring Entity], as shown in the attached duly notarized Special Power of Attorney;

[If a partnership, corporation, cooperative, or joint venture:] I am granted full power and authority to do, execute and perform any and all acts necessary to participate, submit the bid, and to sign and execute the ensuing contract for [Name of the Project] of the [Name of the Procuring Entity], as shown in the attached [state title of attached document showing proof of authorization (e.g., duly notarized Secretary's Certificate, Board/Partnership Resolution, or Special Power of Attorney, whichever is applicable)];

3. [Name of Bidder] is not "blacklisted" or barred from bidding by the Government of the Philippines or any of its agencies, offices, corporations, or Local Government Units, foreign government/foreign or international financing institution whose blacklisting rules have been recognized by the Government Procurement Policy Board, **by itself or by relation, membership, association, affiliation, or controlling interest with another blacklisted person or entity as defined and provided for in the Uniform Guidelines on Blacklisting;**

4. Each of the documents submitted in satisfaction of the bidding requirements is an authentic copy of the original, complete, and all statements and information provided therein are true and correct;

5. [Name of Bidder] is authorizing the Head of the Procuring Entity or its duly authorized representative(s) to verify all the documents submitted;

6. *[Select one, delete the rest:]*

[If a sole proprietorship:] The owner or sole proprietor is not related to the Head of the Procuring Entity, members of the Bids and Awards Committee (BAC), the Technical Working Group, and the BAC Secretariat, the head of the Project Management Office or the end-user unit, and the project consultants by consanguinity or affinity up to the third civil degree;

[If a partnership or cooperative:] None of the officers and members of *[Name of Bidder]* is related to the Head of the Procuring Entity, members of the Bids and Awards Committee (BAC), the Technical Working Group, and the BAC Secretariat, the head of the Project Management Office or the end-user unit, and the project consultants by consanguinity or affinity up to the third civil degree;

[If a corporation or joint venture:] None of the officers, directors, and controlling stockholders of *[Name of Bidder]* is related to the Head of the Procuring Entity, members of the Bids and Awards Committee (BAC), the Technical Working Group, and the BAC Secretariat, the head of the Project Management Office or the end-user unit, and the project consultants by consanguinity or affinity up to the third civil degree;

7. *[Name of Bidder]* complies with existing labor laws and standards; and
8. *[Name of Bidder]* is aware of and has undertaken the responsibilities as a Bidder in compliance with the Philippine Bidding Documents, which includes:
 - a. Carefully examining all of the Bidding Documents;
 - b. Acknowledging all conditions, local or otherwise, affecting the implementation of the Contract;
 - c. Making an estimate of the facilities available and needed for the contract to be bid, if any; and
 - d. Inquiring or securing Supplemental/Bid Bulletin(s) issued for the *[Name of the Project]*.
9. *[Name of Bidder]* did not give or pay directly or indirectly, any commission, amount, fee, or any form of consideration, pecuniary or otherwise, to any person or official, personnel or representative of the government in relation to any procurement project or activity.
10. **In case advance payment was made or given, failure to perform or deliver any of the obligations and undertakings in the contract shall be sufficient grounds to constitute criminal liability for Swindling (Estafa) or the commission of fraud with unfaithfulness or abuse of confidence through misappropriating or converting any payment received by a person or entity under an obligation involving the duty to deliver certain goods or services, to the prejudice of the public and the government of the Philippines pursuant to Article 315 of Act No. 3815 s. 1930, as amended, or the Revised Penal Code.**

IN WITNESS WHEREOF, I have hereunto set my hand this ___ day of ___, 20__ at _____, Philippines.

[Insert NAME OF BIDDER OR ITS AUTHORIZED REPRESENTATIVE]
[Insert signatory's legal capacity]
Affiant

Statement of Single Largest Completed Contract Similar to the Contract to be Bid

This is to certify that _____ **(company)** _____ has the following completed contracts for the period CY 2016-2021.

Name of Contract	a. Date of the Contract b. Date Started c. Date of Completion	a. Owner's Name b. Address c. Telephone Nos.	Kinds of Goods Sold	Amount of Completed Contracts	Date of Delivery	End-user's Acceptance/ Official Receipt/Sales Invoice issued

Name and Signature of
Authorized Representative

Date

Instructions:

- a) Cut-off date as of:
 - i. Up to the day before the deadline of submission of bids.
- b) Largest Contracts to be submitted must be a part of the list.
- c) In the column under "Dates", indicate the dates of Delivery/ End-user's Acceptance and Official Receipt.
- d) "Name of Contract". Indicate here the Nature/ Scope of the Contract for the Procuring Entity to determine the relevance of the entry with the Procurement at hand. Example: "Supply and Delivery of Generator Set"

JOINT VENTURE AGREEMENT

KNOW ALL MEN BY THESE PRESENTS:

This JOINT VENTURE AGREEMENT (hereinafter referred to as the "Agreement"), entered into this _____ day of _____ 20__ at _____ City, Philippines by and among:

_____. a domestic corporation duly organized, registered and existing under and by virtue of the laws of the Republic of the Philippines, with office address at _____, represented by its _____, _____, hereinafter referred to as "_____";

- and -

_____. a domestic corporation duly organized, registered and existing under and by virtue of the laws of the Republic of the Philippines, with office address at _____, represented by its _____, _____, hereinafter referred to as "_____";

- and -

_____ a foreign corporation organized and existing under and by virtue of the laws of _____, represented by its _____, _____, hereinafter referred to as "_____";

(Henceforth collectively referred to as the "Parties")

WITNESSETH: That

WHEREAS, the Procurement Service (PS) has recently published an Invitation to Apply for Eligibility and to Bid for the Supply and Delivery of _____ for the _____;

WHEREAS, the parties have agreed to pool their resources together to form the “
_____ Joint Venture”, hereinafter referred to as the Joint Venture, under the laws
of the Philippines, for the purpose of participating in the abovementioned procurement of PS-
DBM;

NOW, THEREFORE, for and in consideration of the foregoing premises and the covenants
hereto set forth, the Parties have agreed as follows:

ARTICLE I ORGANIZATION OF THE JOINT VENTURE

SECTION 1. Formation – The Parties do hereby agree and bind themselves to establish, form and
organize a Joint Venture pursuant to the laws of the Republic of the Philippines, in order for the
JV to carry on the purposes and objectives for which it is created;

SECTION 2. Name – The name and style under which the JV shall be conducted is “
_____”;

SECTION 3. Principal Place of Business – The JV shall maintain its principal place of
business at _____;

SECTION 4. Preparation and Documentation – The Parties shall secure and/or execute such
certifications, documents, deeds and instruments as may be required by the laws of the Republic
of the Philippines for the realization of the JV and in compliance with the Project. Further, they
shall do all other acts and things requisite for the continuation of the JV pursuant to applicable
laws;

SECTION 5. The Joint Venture shall be represented by the _____ in all biddings,
related procurement transactions and other official dealings that it shall enter into with the
PS-DBM and third parties, such transactions to include, among others, the submission of
eligibility documents, bids, registration documents obtaining bonds, performing the
principal contract in the event that the contract is awarded in favor of the Joint Venture,
receipt of payment for goods delivered, and similar and related activities.

SECTION 6. The period of the Joint Venture shall begin upon execution of this Agreement
and shall continue until the complete performance of its contractual obligations to PS-
DBM, as described in Article II hereof, or upon its termination for material breach of any
term or condition of this Agreement, by service of a written statement in English on the
other Party, not less than 90 days prior to the intended date termination

ARTICLE II PURPOSE

SECTION 1. The primary purpose of the Joint Venture is to participate in the public
bidding to be conducted by the DBM-PS Bids and Awards Committee for the supply and
delivery of _____ for the _____.

SECTION 2. If the above-described contract/s is/are awarded to the Joint Venture, the Joint Venture shall undertake the performance thereof to PS-DBM, and such other incidental activities necessary for the completion of its contractual obligations.

**ARTICLE III
SOLIDARY LIABILITY OF THE PARTIES**

SECTION 1. In the performance of the contract/s that may be awarded to the Joint Venture by the PS-DBM, and all other related activities/obligations, as described in Article II hereof, the Parties bind themselves jointly and solidarily, in the concept of solidarily debtors, subject to the right of reimbursement, as provided in the relevant provisions of the Civil Code of the Philippines.

**ARTICLE IV
CONTRIBUTION AND OTHER ARRANGEMENTS**

SECTION 1. Contribution – The Parties shall contribute the amount of _____(Php) to support the financial requirements of the Joint Venture, in the following proportion:

A.	-	P	.00
B.	-	<u>P</u>	<u>.00</u>
TOTAL		P	.00

Additional contributions to the Joint Venture shall be made as may be required for contract implementation. In addition, shall contribute any labor and contract management requirements.

SECTION 2. Profit Sharing – The share of the Parties to the JV from any profit derived or obtained from the implementation and execution of the Project shall be distributed pro rata to each, in accordance with the contribution and resources each has provided to the JV;

SECTION 3. Liquidation and Distributions – Any sum remaining after deducting from the total of all moneys or benefits received for the performance of the contract, all costs incurred by the JV after award of the contract for the Project pursuant to the accounting practices established for the JV, shall be distributed in accordance with the relative balances in the accounts of each Party pursuant to Sec.1 of this Article upon completion, final accounting, termination and liquidation of the JV. In the event of liquidation and termination of JV, and after taking into account the shares of the Parties in all income, gain, deductions, expenses, and losses, should the account of a Party contain a negative balance, such Party shall contribute cash to the JV sufficient to restore the said balance to zero;

SECTION 4. Sharing of Burden of a Net Loss – In case a net loss is incurred, additional contributions shall be made by the Parties in accordance with their respective shares.

**ARTICLE V
MISCELLANEOUS PROVISIONS**

SECTION 1. The provisions of the Instructions to Bidders, Supplemental Bid Bulletin, and other bidding documents issued by the PS-DBM in relation to the contract described in Article II hereof, shall be deemed incorporated in this Agreement and made an integral part thereof.

SECTION 2. This Agreement shall be binding upon and inure to the benefit of the Parties and their respective successors and assigns.

SECTION 3. The Parties herein are duly represented by their authorized officers.

SECTION 4. Governing Law - This Agreement shall be governed by and construed according to the laws of the Republic of the Philippines. Venue of any court action arising from this Agreement shall be exclusively laid before the proper court of the _____, Philippines.

IN WITNESS WHEREOF, the parties have set their hands and affixed their signatures on the date and place first above-stated.

Signed in the Presence of:

ACKNOWLEDGMENT

REPUBLIC OF THE PHILIPPINES)
CITY/MUNICIPALITY OF _____) S.S.
PROVINCE OF (in the case of Municipality)

BEFORE ME, a Notary Public for and in the City/Municipality of _____ (indicate also the Province in the case of Municipality), this _____ day of (month & year) _____ personally appeared the following:

Name ID Name, Number and Validity Date

Known to me and to me known to be the same persons who executed the foregoing instrument and they acknowledge to me that the same is their free and voluntary act and deed and that of the corporation(s) they represent.

This instrument refers to a Joint Venture Agreement consisting of _____ pages, including the page on which this Acknowledgement is written, and signed by the parties and their instrumental witnesses.

WITNESS MY HAND AND NOTARIAL SEAL on the place and on the date first above written.

NAME OF NOTARY PUBLIC
Serial No. of Commission _____
Notary Public for _____ until _____ Roll of
Attorneys No. _____
PTR No. , [date issued], [place issued]
IBP No. , [date issued], [place issued]

Doc. No. Page No.
Book No. Series of .

Note:

The identification card shall be at least one of those acceptable proofs of identity as identified under the provisions of the 2004 Rules on Notarial Practice.

“Sec. 12. Competent Evidence of Identity – The phrase “competent evidence of identity” refers to the identification of an individual based on:

At least one current identification document issued by an official agency bearing the photograph and signature of the individual, such as but not limited to, passport, driver’s license, Professional Regulations Commission ID, National Bureau of Investigation clearance, police clearance, postal ID, voter’s ID, Barangay certification, Government Service and Insurance System (GSIS) e-card, Social Security System (SSS) card, Philhealth card, senior citizen card, Overseas Workers Welfare Administration (OWWA) ID, OFW ID, seaman’s book, alien certificate of registration/immigrant certificate of registration, government office ID, certification from the National Council for the Welfare of Disabled Persons (NCWDP), Department of Social Welfare and Development (DSWD) certification

SUPPLIER'S LETTERHEAD

Date

BAC Chairperson
PPA PMO Agusan
Talisay, Nasipit, Agusan del Norte

Dear Sir:

This has reference to Public Bidding No. _____ for _____ (Name of Project) _____.

(Name of Company) respectfully requests for the following:

- Withdraw of Bid Submissions ()
- Refund of Bid Security
(Attached is a photocopy of the Procurement Service Official Receipt) ()
- Cancellation of Credit Line Certificate

It is understood that _____ waives its right to file any motion for reconsideration and/pr protest in connection with the above-cited Public Bidding Project.

Thank you.

Very truly yours,

Authorized Signatory for the Company

Form of Performance Security (Bank Guarantee)

To : PPA PMO Agusan
Brgy. Talisay,
Nasipit, Agusan del Norte

WHEREAS, _____ (Name and Address of Supplier) (hereinafter called "the Supplier") has undertaken, in pursuance of Notice of Award No. _____ dated _____ to execute (Name of Contract and Brief Description) (hereinafter called "the Contract");

AND WHEREAS, it has been stipulated by you in the said Contract that the Supplier shall furnish you with a Bank Guarantee by a recognized bank for the sum specified therein as security for compliance with his obligations in accordance with the Contract;

AND WHEREAS, we have agreed to give the Supplier such a Bank Guarantee;

NOW THEREFORE, we hereby affirm that we are the Guarantor and responsible to you, on behalf of the Supplier, up to a total of [Amount of Guarantee] proportions of currencies in which the Contract Price is payable, and we undertake to pay you, upon your first written demand and without cavil or argument, any sum or sums within the limits of [Amount of Guarantee] as aforesaid without your needing to prove or to show grounds or reasons for your demand for the sum specified therein.

We hereby waive the necessity of your demanding the said debt from the Supplier before presenting us with the demand.

We further agree that no change or addition to or other modification of the terms of the Contract to be performed thereunder or of any of the Contract documents which may be made between you and the Supplier shall in any way release us from any liability under this guarantee, and we hereby waive notice of any such change, addition or modification.

This guarantee shall be valid until the date of issue of the Final Acceptance [Inspection, & Certification of Acceptance Report(I.C.A.R)].

SIGNATURE AND SEAL OF THE
GUARANTOR
NAME OF BANK
ADDRESS
DATE

BID SECURING DECLARATION FORM

REPUBLIC OF THE PHILIPPINES)
CITY OF _____) S.S.

x-----x

BID SECURING DECLARATION Invitation to Bid: Public Bidding No. 006-2021

To: Procurement Service
PS Complex, RR Road
Cristobal St., Paco, Manila

I/We¹, the undersigned, declare that:

1. I/We understand that, according to your conditions, bids must be supported by a Bid Security, which may be in the form of a Bid-Securing Declaration.
2. I/We accept that: (a) I/we will be automatically disqualified from bidding for any contract with any procuring entity for a period of two (2) years upon receipt of your Blacklisting order; and, (b) I/we will pay the applicable fine provided under Section 6 of the Guidelines on the Use of Bid Securing Declaration, within fifteen (15) days from receipt of the written demand by the procuring entity for the commission of acts resulting to the enforcement of the bid securing declaration under Sections 23.1(b), 34.2, 40.1 and 69.1, except 69.1(f), of the IRR of RA 9184; without prejudice to other legal action the government may undertake.
3. I/We understand that this Bid Securing Declaration shall cease to be valid on the following circumstances:
 - (a) Upon expiration of the bid validity period, or any extension thereof pursuant to your request;
 - (b) I am/we are declared ineligible or post-disqualified upon receipt of your notice to such effect, and (i) I/we failed to timely file a request for reconsideration or (ii) I/we filed a waiver to avail of said right;
 - (c) I am/we are declared the bidder with the Lowest Calculated Responsive Bid, and I/we have furnished the performance security and signed the Contract.

IN WITNESS WHEREOF, I/We have hereunto set my/our hand/s this _____ day of
[month] [year] at [place of execution].

¹ Select one and delete the other. Adopt the same instruction for similar terms throughout the document.

[Insert NAME OF BIDDER'S AUTHORIZED
REPRESENTATIVE]
[Insert Signatory's Legal Capacity]

Affiant

SUBSCRIBED AND SWORN to before me this ____ day of [month] [year] at [place of execution], Philippines. Affiant/s known to me, and known to be the same person/s in the exhibited [insert type of government identification card used*], with his/her photograph and signature appearing thereon, with no. _____ issued on _____ at _____.

Witness my hand and seal this ____ day of [month] [year].

NAME OF NOTARY PUBLIC

Serial No. of Commission _____

Notary Public for _____ until _____

Roll of Attorney's No. _____

PTR No. _____ [date issued], [place issued]

IBP No. _____ [date issued], [place issued]

Doc. No. _____

Page No. _____

Book No. _____

Series of _____

*The identification card shall be at least one of those acceptable proofs of identity as identified under the provisions of the 2004 Rules on Notarial Practice.

“Sec. 12. Competent Evidence of Identity – The phrase “competent evidence of identity” refers to the identification of an individual based on:

At least one current identification document issued by an official agency bearing the photograph and signature of the individual, such as but not limited to, passport, driver's license, Professional Regulations Commission ID, National Bureau of Investigation clearance, police clearance, postal ID, voter's ID, Barangay certification, Government Service and Insurance System (GSIS) e-card, Social Security System (SSS) card, Philhealth card, senior citizen card, Overseas Workers Welfare Administration (OWWA) ID, OFW ID, seaman's book, alien certificate of registration/immigrant certificate of registration, government office ID, certification from the National Council for the Welfare of Disabled Persons (NCWDP), Department of Social Welfare and Development (DSWD) certification

Performance Securing Declaration (Revised)

[if used as an alternative performance security but it is not required to be submitted with the Bid, as it shall be submitted within ten (10) days after receiving the Notice of Award]

REPUBLIC OF THE PHILIPPINES)
CITY OF _____) S.S.

PERFORMANCE SECURING DECLARATION

Invitation to Bid: [Insert Reference Number indicated in the Bidding Documents]

To: [Insert name and address of the Procuring Entity]

I/We, the undersigned, declare that:

1. I/We understand that, according to your conditions, to guarantee the faithful performance by the supplier/distributor/manufacturer/contractor/consultant of its obligations under the Contract, I/we shall submit a Performance Securing Declaration within a maximum period of ten (10) calendar days from the receipt of the Notice of Award prior to the signing of the Contract.
2. I/We accept that: I/we will be automatically disqualified from bidding for any procurement contract with any procuring entity for a period of one (1) year for the first offense, or two (2) years for the second offense, upon receipt of your Blacklisting Order if I/We have violated my/our obligations under the Contract;
3. I/We understand that this Performance Securing Declaration shall cease to be valid upon:
 - a. issuance by the Procuring Entity of the Certificate of Final Acceptance, subject to the following conditions:
 - i. Procuring Entity has no claims filed against the contract awardee;
 - ii. It has no claims for labor and materials filed against the contractor; and
 - iii. Other terms of the contract; or
 - b. replacement by the winning bidder of the submitted PSD with a performance security in any of the prescribed forms under Section 39.2 of the 2016 revised IRR of RA No. 9184 as required by the end-user.

IN WITNESS WHEREOF, I/We have hereunto set my/our hand/s this _____ day of [month] [year] at [place of execution].

[Insert NAME OF BIDDER'S AUTHORIZED REPRESENTATIVE]

[Insert Signatory's Legal Capacity]
Affiant

SUBSCRIBED AND SWORN to before me this ____ day of [month] [year] at [place of execution], Philippines. Affiant/s known to me, and known to be the same person/s in the exhibited [insert type of government identification card used*], with his/her photograph and signature appearing thereon, with no. _____ issued on _____ at _____.

Witness my hand and seal this ____ day of [month] [year].

NAME OF NOTARY PUBLIC

Serial No. of Commission _____

Notary Public for _____ until _____

Roll of Attorney's No. _____

PTR No. _____ [date issued], [place issued]

IBP No. _____ [date issued], [place issued]

Doc. No. _____

Page No. _____

Book No. _____

Series of _____

***The identification card shall be at least one of those acceptable proofs of identity as identified under the provisions of the 2004 Rules on Notarial Practice.**

“Sec. 12. Competent Evidence of Identity – The phrase “competent evidence of identity” refers to the identification of an individual based on:

At least one current identification document issued by an official agency bearing the photograph and signature of the individual, such as but not limited to, passport, driver’s license, Professional Regulations Commission ID, National Bureau of Investigation clearance, police clearance, postal ID, voter’s ID, Barangay certification, Government Service and Insurance System (GSIS) e-card, Social Security System (SSS) card, Philhealth card, senior citizen card, Overseas Workers Welfare Administration (OWWA) ID, OFW ID, seaman’s book, alien certificate of registration/immigrant certificate of registration, government office ID, certification from the National Council for the Welfare of Disabled Persons (NCWDP), Department of Social Welfare and Development (DSWD) certification

Contract Agreement Form for the Procurement of Goods (Revised)

[Not required to be submitted with the Bid, but it shall be submitted within ten (10) days after receiving the Notice of Award]

CONTRACT AGREEMENT

THIS AGREEMENT made the _____ day of _____ 20____ between [name of PROCURING ENTITY] of the Philippines (hereinafter called "the Entity") of the one part and [name of Supplier] of [city and country of Supplier] (hereinafter called "the Supplier") of the other part;

WHEREAS, the Entity invited Bids for certain goods and ancillary services, particularly [brief description of goods and services] and has accepted a Bid by the Supplier for the supply of those goods and services in the sum of [contract price in words and figures in specified currency] (hereinafter called "the Contract Price").

NOW THIS AGREEMENT WITNESSETH AS FOLLOWS:

1. In this Agreement words and expressions shall have the same meanings as are respectively assigned to them in the Conditions of Contract referred to.
2. The following documents as required by the 2016 revised Implementing Rules and Regulations of Republic Act No. 9184 shall be deemed to form and be read and construed as integral part of this Agreement, viz.:
 - i. Philippine Bidding Documents (PBDs);
 - i. Schedule of Requirements;
 - ii. Technical Specifications;
 - iii. General and Special Conditions of Contract; and
 - iv. Supplemental or Bid Bulletins, if any
- ii. Winning bidder's bid, including the Eligibility requirements, Technical and Financial Proposals, and all other documents or statements submitted;

Bid form, including all the documents/statements contained in the Bidder's bidding envelopes, as annexes, and all other documents submitted (e.g., Bidder's response to request for clarifications on the bid), including corrections to the bid, if any, resulting from the Procuring Entity's bid evaluation;
- iii. Performance Security;
- iv. Notice of Award of Contract; and the Bidder's conforme thereto; and
- v. Other contract documents that may be required by existing laws and/or the Procuring Entity concerned in the PBDs. Winning bidder agrees that additional contract documents or information prescribed by the GPPB that are subsequently required for submission after the contract execution, such as the Notice to Proceed, Variation Orders, and Warranty Security, shall likewise form part of the Contract.

3. In consideration for the sum of [totalcontract price in words and figures] or such other sums as may be ascertained, [Named of the bidder] agrees to [state the object of the contract] in accordance with his/her/its Bid.
4. The [Name of the procuring entity] agrees to pay the above-mentioned sum in accordance with the terms of the Bidding.

IN WITNESS whereof the parties hereto have caused this Agreement to be executed in accordance with the laws of the Republic of the Philippines on the day and year first above written.

[Insert Name and Signature]	[Insert Name and Signature]
[Insert Signatory's Legal Capacity]	[Insert Signatory's Legal Capacity]
for:	for:
[Insert Procuring Entity]	[Insert Name of Supplier]

ACKNOWLEDGMENT

REPUBLIC OF THE PHILIPPINES)
 CITY/MUNICIPALITY OF _____) S.S.
 PROVINCE OF (in the case of Municipality)

BEFORE ME, a Notary Public for and in the City/Municipality of _____ (indicate also the Province in the case of Municipality), this _____ day of (month & year) _____ personally appeared the following:

Name	ID Name, Number and Validity Date
------	-----------------------------------

Known to me and to me known to be the same persons who executed the foregoing instrument and they acknowledge to me that the same is their free and voluntary act and deed and that of the corporation(s) they represent.

This instrument refers to a Joint Venture Agreement consisting of _____ pages, including the page on which this Acknowledgement is written, and signed by the parties and their instrumental witnesses.

WITNESS MY HAND AND NOTARIAL SEAL on the place and on the date first above written.
 NAME OF NOTARY PUBLIC

Serial No. of Commission _____
Notary Public for _____ until _____
Roll of Attorneys No. _____
PTR No. , [date issued], [place issued]
IBP No. , [date issued], [place issued]

Doc. No. Page
No. Book No.
Series of .

Note:

The identification card shall be at least one of those acceptable proofs of identity as identified under the provisions of the 2004 Rules on Notarial Practice.

“Sec. 12. Competent Evidence of Identity – The phrase “competent evidence of identity” refers to the identification of an individual based on:

At least one current identification document issued by an official agency bearing the photograph and signature of the individual, such as but not limited to, passport, driver’s license, Professional Regulations Commission ID, National Bureau of Investigation clearance, police clearance, postal ID, voter’s ID, Barangay certification, Government Service and Insurance System (GSIS) e-card, Social Security System (SSS) card, Philhealth card, senior citizen card, Overseas Workers Welfare Administration (OWWA) ID, OFW ID, seaman’s book, alien certificate of registration/immigrant certificate of registration, government office ID, certification from the National Council for the Welfare of Disabled Persons (NCWDP), Department of Social Welfare and Development(DSWD)certification



PERSPECTIVE

NOT TO SCALE

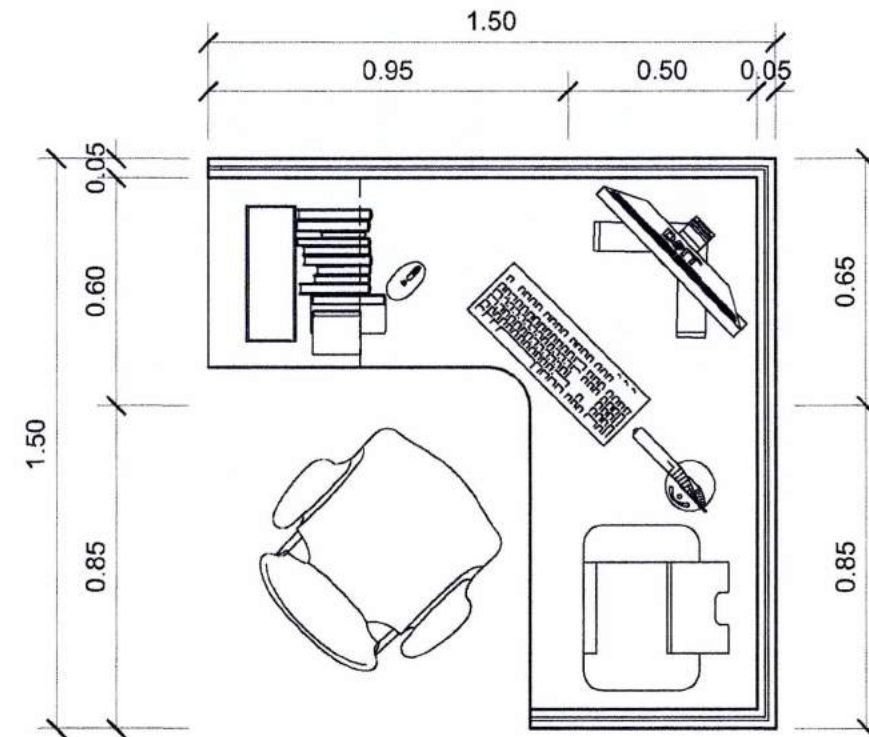

FLOOR PLAN (JUNIOR)

SCALE: 1:20 MTS.

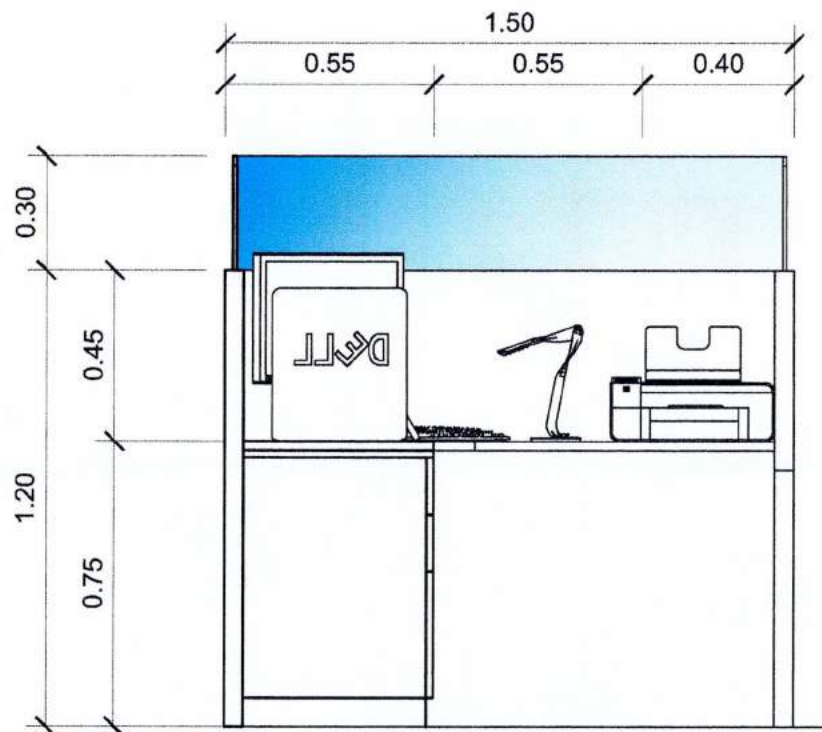

FRONT ELEV.

SCALE: 1:20 MTS.

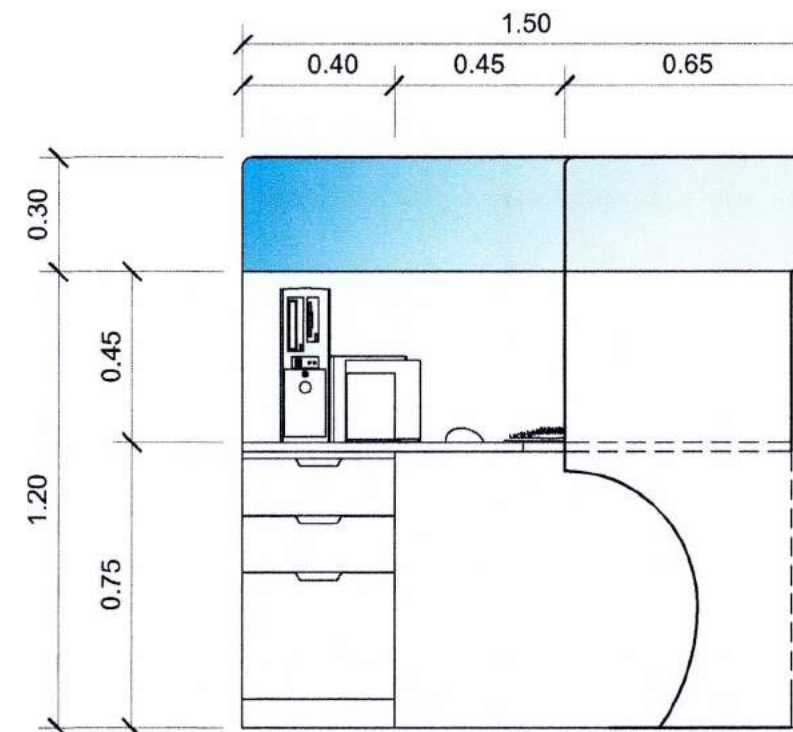

LEFT SIDE ELEV.

SCALE: 1:20 MTS.



Project / Location:
**SUPPLY, DELIVERY AND
 INSTALLATION OF MODULAR
 TABLES**
 PORT OF NASIPIT
 NASIPIT, AGUSAN DEL NORTE

Submitted by:

MA. GEMMA MAE A. AGUILAR
 DRAFTSMAN

Checked by:

AMALIA M. DUMANON
 CONSTRUCTION FOREMAN A

Reviewed by:

VINCENT JUDE A. PORIO
 SENIOR ENGINEER A /
 ACTING SUPERVISING ENGINEER A

Recommending Approval:

ATTY. KAHLIL L. LAMIGO
 ACTING DIVISION MANAGER A, ASD

BELTZASAR L. GELLA
 ACTING DIVISION MANAGER A, ESD

Approved by:

MILDRED J. PADILLA
 PORT MANAGER

Sheet Contents:
 • PERSPECTIVE
 MODEL
 • FLOOR PLAN
 • ELEVATIONS

Sheet No.
01
07
 AUGUST 2021
 MGMA



PERSPECTIVE

NOT TO SCALE

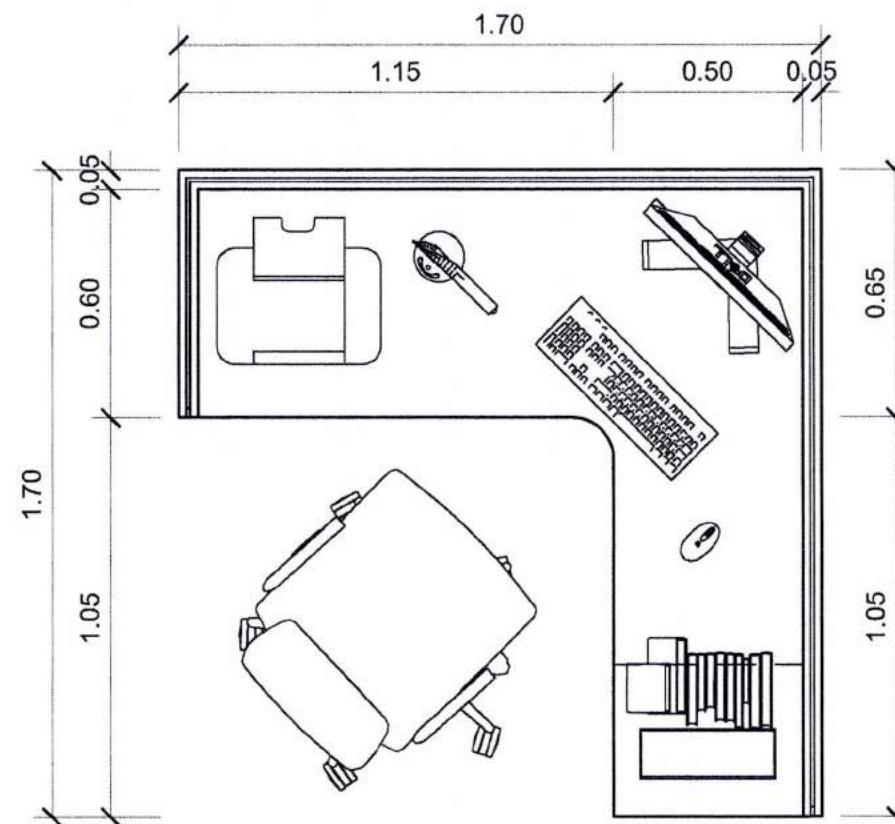

FLOOR PLAN (SENIOR)

SCALE: 1:20 MTS.

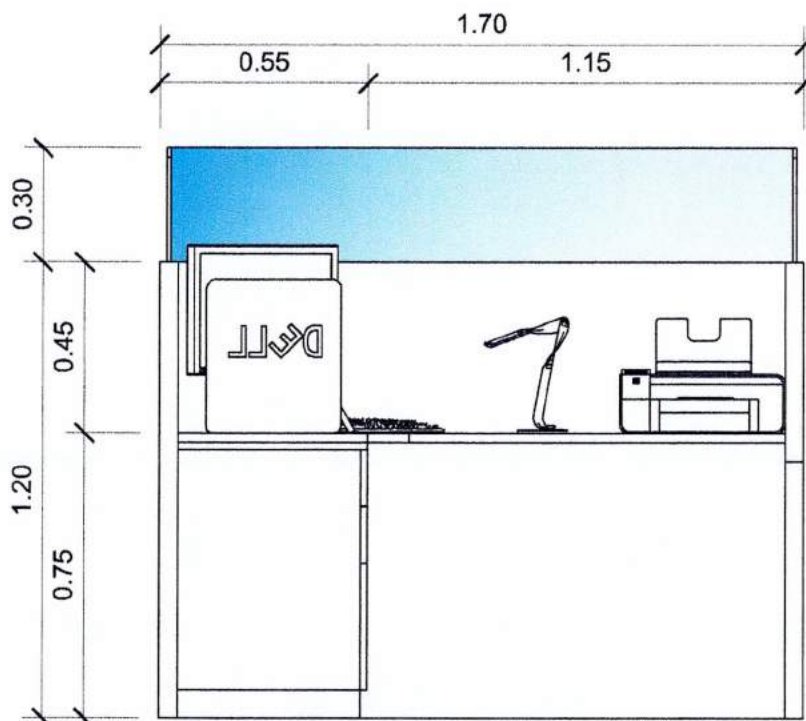



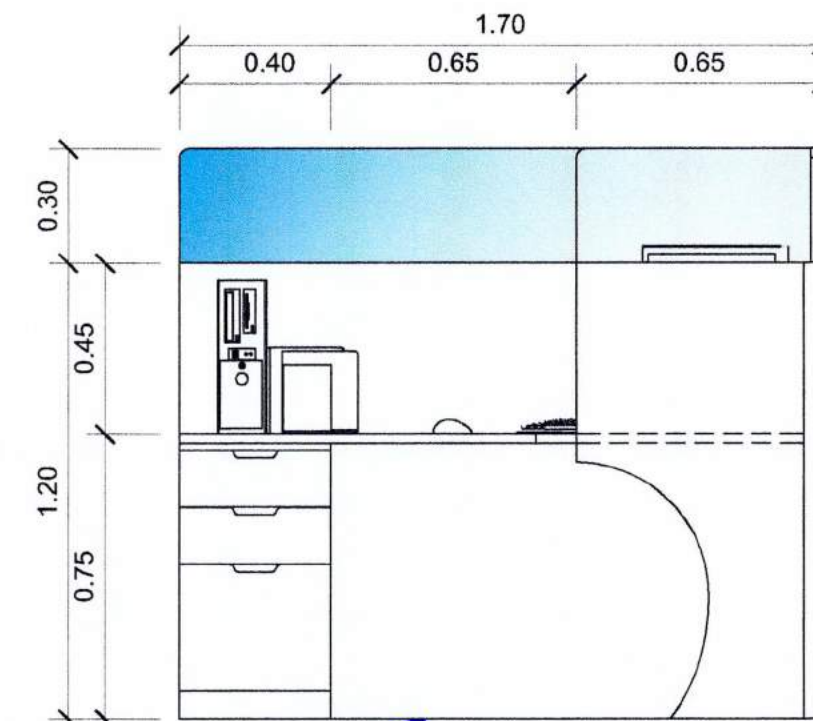

FRONT ELEV.

SCALE: 1:20 MTS.

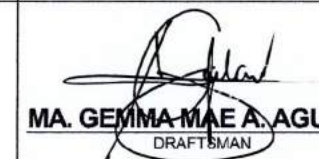

LEFT SIDE ELEV.

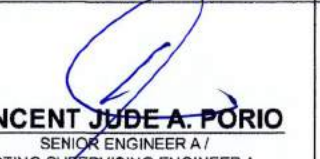
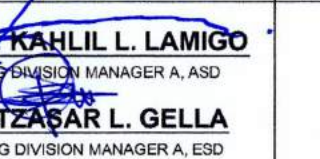
SCALE: 1:20 MTS.

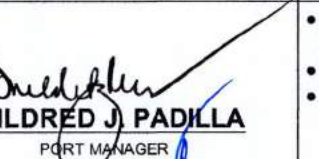
	Project / Location:	Submitted by:	Checked by:	Reviewed by:	Recommending Approval:	Approved by:	Sheet Contents:	Sheet No.
	SUPPLY, DELIVERY AND INSTALLATION OF MODULAR TABLES PORT OF NASIPIT NASIPIT, AGUSAN DEL NORTE	 MA. GEMMA MAE A. AGUILAR DRAFTSMAN	 AMALIA M. DUMANON CONSTRUCTION FOREMAN A	 VINCENT JUDE A. PORIO SENIOR ENGINEER A / ACTING SUPERVISING ENGINEER A	 ATTY. KAHLIL L. LAMIGO ACTING DIVISION MANAGER A, ASD  BELTZASAR L. GELLA ACTING DIVISION MANAGER A, ESD	 MILDRED J. PADILLA PORT MANAGER	• PERSPECTIVE MODEL • FLOOR PLAN • ELEVATIONS	02 07 AUGUST 2021 MGMA

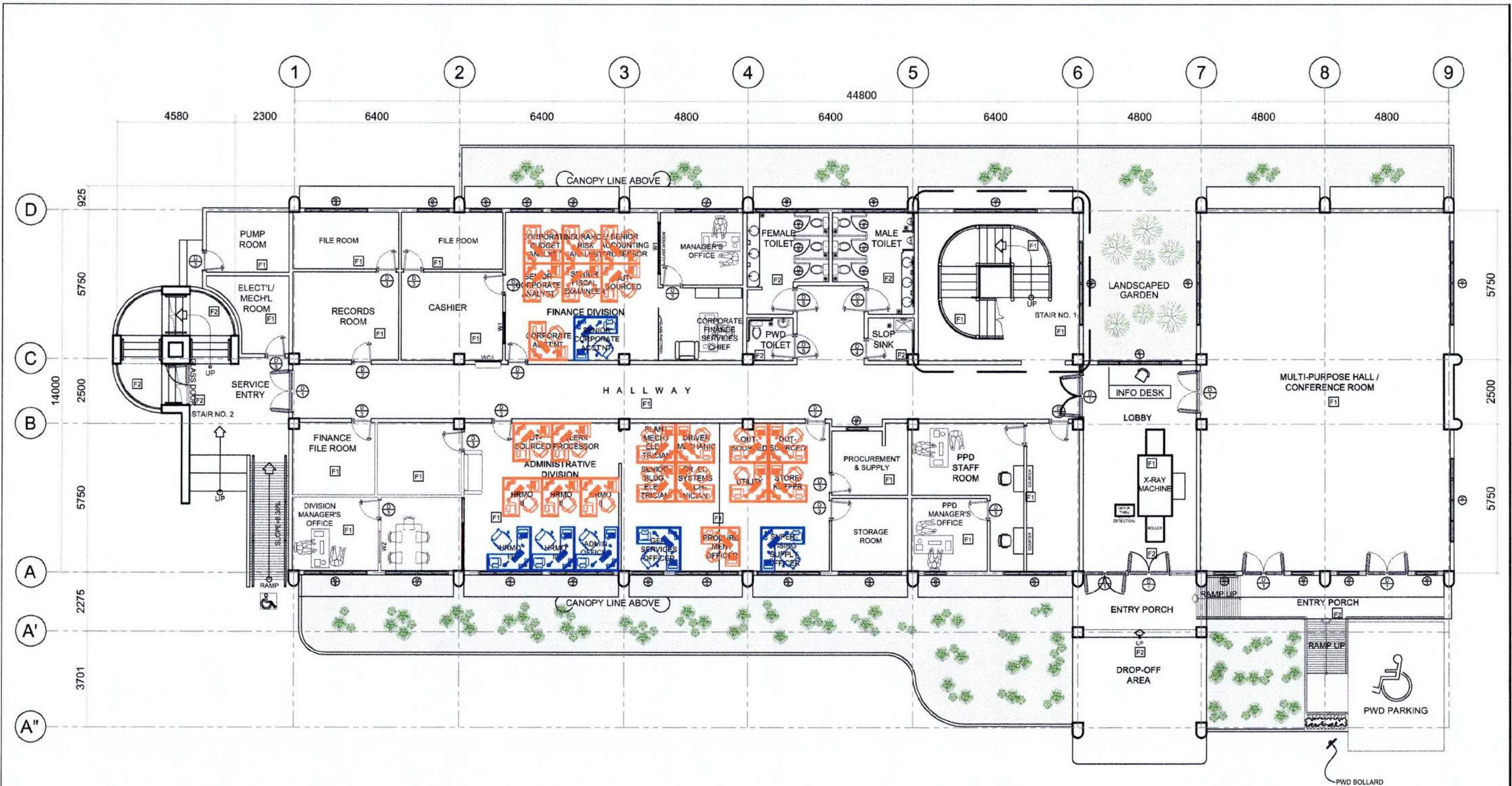

POB GROUND FLOOR PLAN
 SCALE: 1:100 MTS.

- LEGEND:**
- JUNIOR MODULAR TABLE
 - SENIOR MODULAR TABLE

	Project / Location:	Submitted by:	Checked by:	Reviewed by:	Recommending Approval:	Approved by:	Sheet Contents:	Sheet No.
	SUPPLY, DELIVERY AND INSTALLATION OF MODULAR TABLES AT PORT POLICE DIVISION OFFICE PORT OF NASIPIT <small>NASIPIT, AGUSAN DEL NORTE</small>	 MA. GEMMA MAE A. AGUILAR <small>DRAFTSMAN</small>	 AMALIA M. DUMANON <small>CONSTRUCTION FOREMAN A</small>	 VINCENT JUDE A. PORIO <small>SENIOR ENGINEER A / ACTING SUPERVISING ENGINEER A</small>	 ATTY. KAHILIL L. LAMIGO <small>ACTING DIVISION MANAGER A, ASD</small> BELTZASAR L. GELLA <small>ACTING DIVISION MANAGER A, ESD</small>	 MILDRED J. PADILLA <small>PORT MANAGER</small>	POB GROUND FLOOR PLAN (MODULAR TABLE BUILDING LAYOUT PLAN)	03 07 <small>AUGUST 2021 MGMA</small>

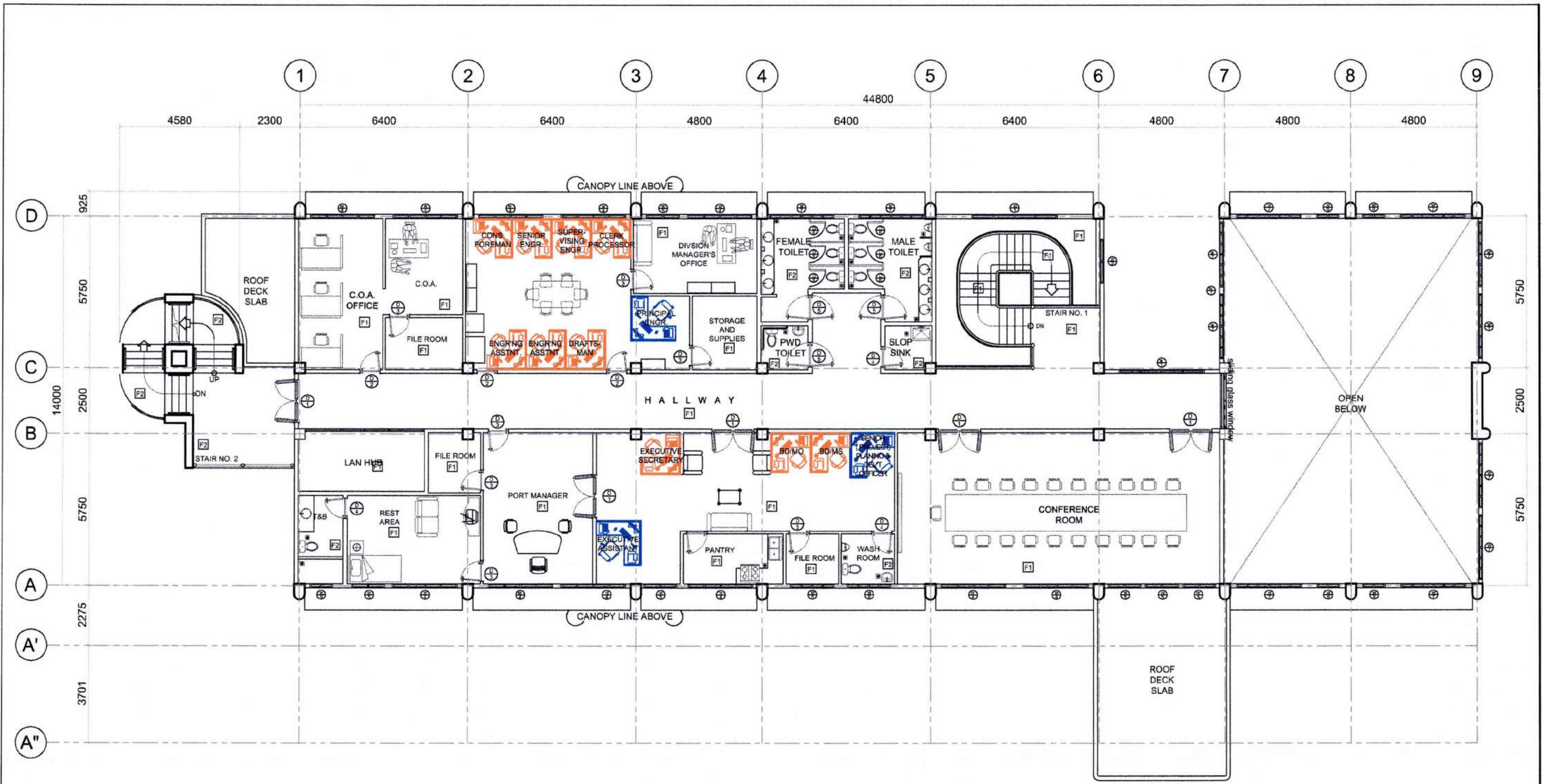

POB SECOND FLOOR PLAN
 SCALE: 1:100 MTS.

LEGEND:
 - JUNIOR MODULAR TABLE
 - SENIOR MODULAR TABLE



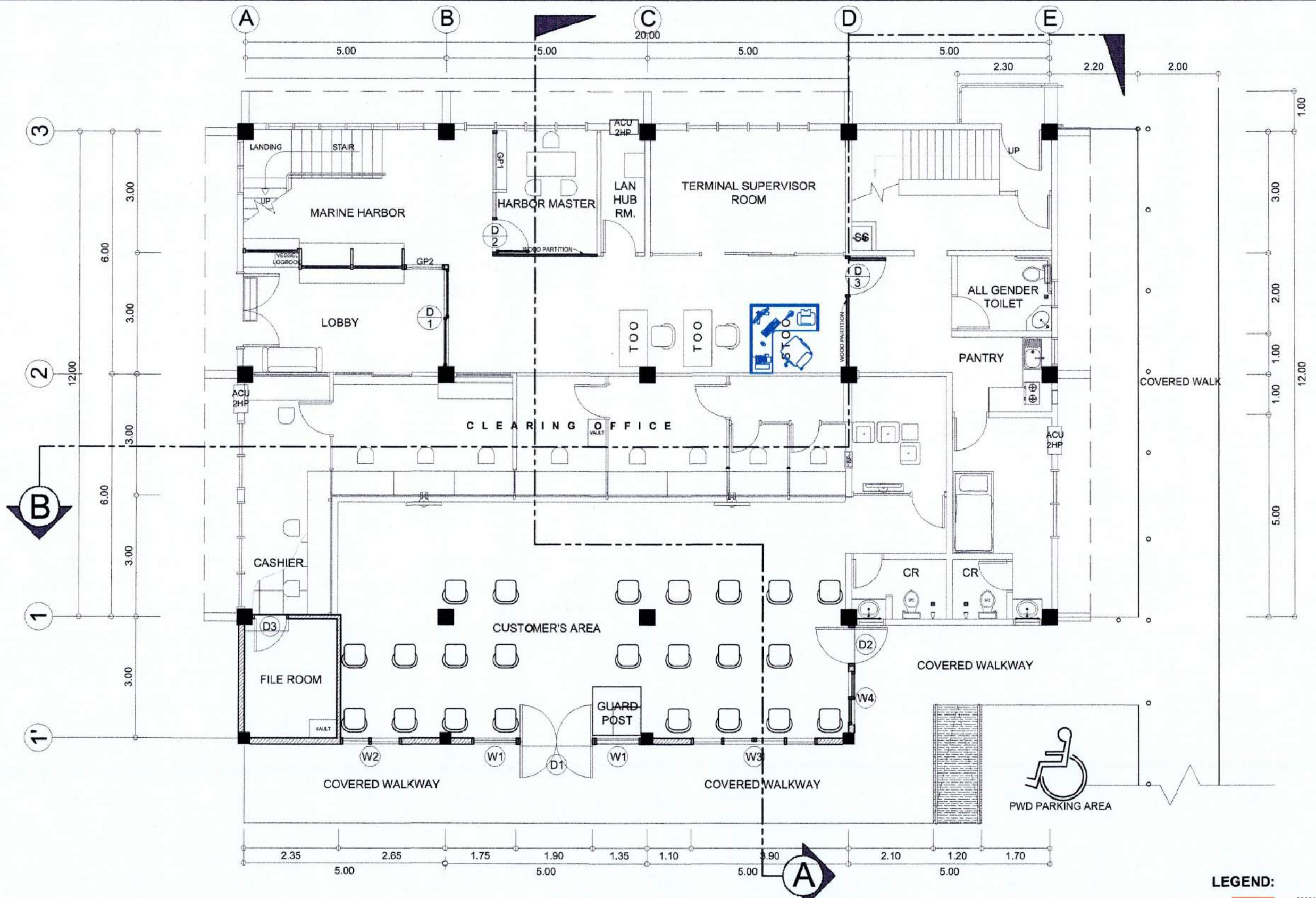



	Project / Location:	Submitted by:	Checked by:	Reviewed by:	Recommending Approval:	Approved by:	Sheet Contents:	Sheet No.
	SUPPLY, DELIVERY AND INSTALLATION OF MODULAR TABLES AT PORT POLICE DIVISION OFFICE PORT OF NASIPIT <small>NASIPIT, AGUSAN DEL NORTE</small>	 MA. GEMMA MAE A. AGUILAR <small>DRAFTSMAN</small>	 AMALIA M. DUMANON <small>CONSTRUCTION FOREMAN A</small>	 VINCENT JUDE A. PORIO <small>SENIOR ENGINEER A / ACTING SUPERVISING ENGINEER A</small>	 ATTY. KAHLIL L. LAMIGO <small>ACTING DIVISION MANAGER A, ASD</small> BELTZASAR L. GELLA <small>ACTING DIVISION MANAGER A, ESD</small>	 MILDRED J. PADILLA <small>PORT MANAGER</small>	POB SECOND FLOOR PLAN (MODULAR TABLE BUILDING LAYOUT PLAN)	04 07 <small>AUGUST 2021 MGMA</small>

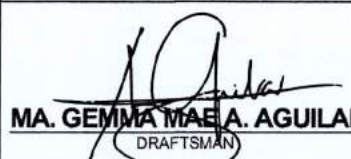

PICO GROUND FLOOR PLAN

SCALE: 1:100 MTS.

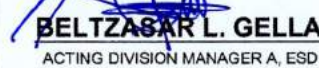
- LEGEND:**
- JUNIOR MODULAR TABLE
 - SENIOR MODULAR TABLE

	Project / Location:	Submitted by:	Checked by:	Reviewed by:	Recommending Approval:	Approved by:	Sheet Contents:	Sheet No.
	SUPPLY, DELIVERY AND INSTALLATION OF MODULAR TABLES AT PORT POLICE DIVISION OFFICE PORT OF NASIPIT NASIPIT, AGUSAN DEL NORTE	 MA. GEMMA MAE A. AGUILAR DRAFTSMAN	 AMALIA M. DUMANON CONSTRUCTION FOREMAN A	 VINCENT JUDE A. PORIO SENIOR ENGINEER A / ACTING SUPERVISING ENGINEER A	 ATTY. KANLIL L. LAMIGO ACTING DIVISION MANAGER A, ASD  BELTZASAR L. GELLA ACTING DIVISION MANAGER A, ESD	 MILDRED J. PADILLA PORT MANAGER	PICO GROUND FLOOR PLAN (MODULAR TABLE BUILDING LAYOUT PLAN)	05 07 AUGUST 2021 MGMA

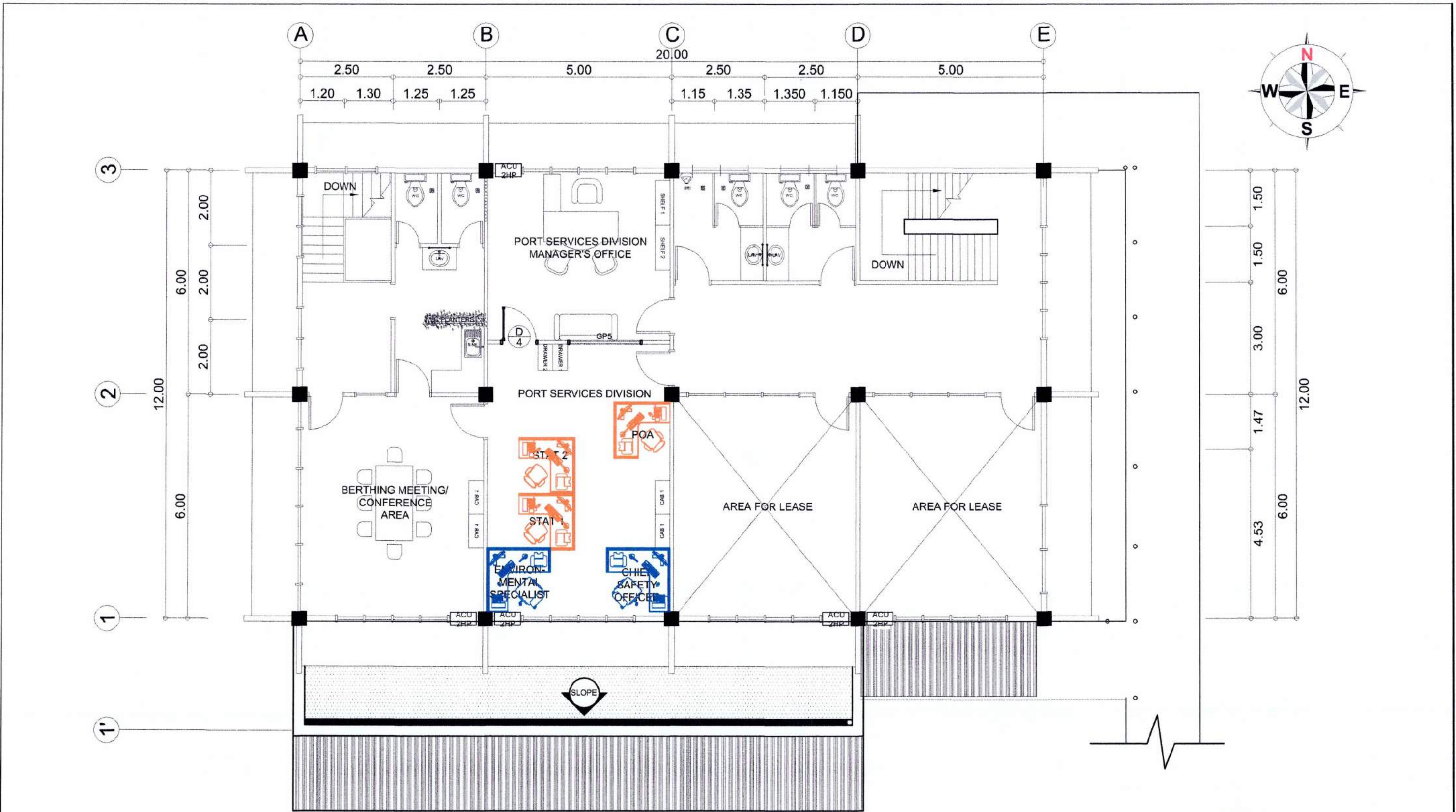

PICO SECOND FLOOR PLAN

SCALE: 1:100 MTS.

- LEGEND:**
- JUNIOR MODULAR TABLE
 - SENIOR MODULAR TABLE

	Project / Location:	Submitted by:	Checked by:	Reviewed by:	Recommending Approval:	Approved by:	Sheet Contents:	Sheet No.
	SUPPLY, DELIVERY AND INSTALLATION OF MODULAR TABLES AT PORT POLICE DIVISION OFFICE PORT OF NASIPIT NASIPIT, AGUSAN DEL NORTE	 MA. GEMMA MAE A. AGUILAR DRAFTER/SMAN	 AMALIA M. DUMANON CONSTRUCTION FOREMAN A	 VINCENT JUDE A. PORIO SENIOR ENGINEER A / ACTING SUPERVISING ENGINEER A	 ATTY. KAHILIL L. LAMIGO ACTING DIVISION MANAGER A, ASD BELTZASAR L. GELLA ACTING DIVISION MANAGER A, ESD	 MILDRED J. PADILLA PORT MANAGER	PICO SECOND FLOOR PLAN (MODULAR TABLE BUILDING LAYOUT PLAN)	06 07 AUGUST 2021 MGMA

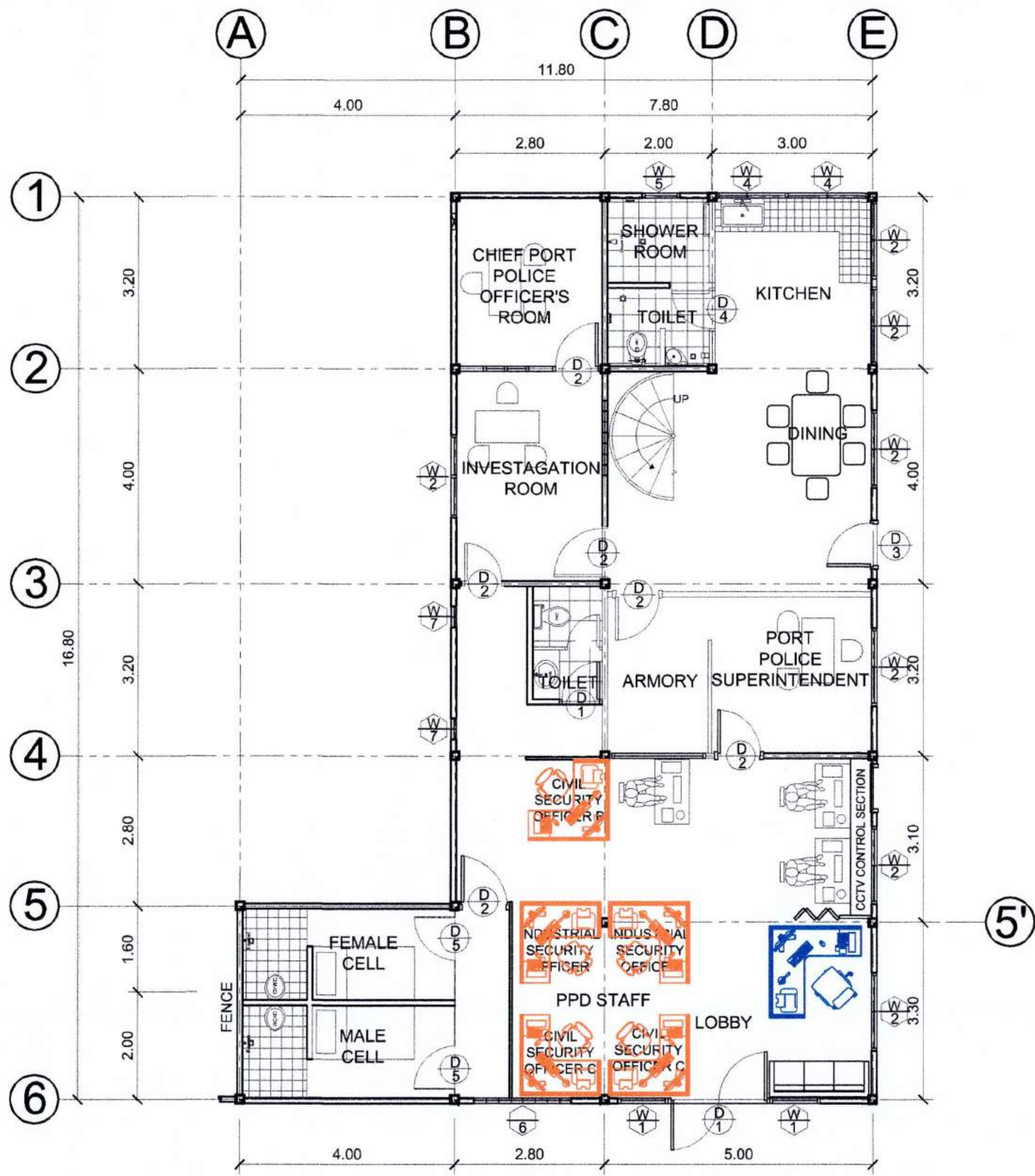

PPD GROUND FLOOR PLAN

SCALE: 1:100 MTS.

- LEGEND:**
- JUNIOR MODULAR TABLE
 - SENIOR MODULAR TABLE

	Project / Location:	Submitted by:	Checked by:	Reviewed by:	Recommending Approval:	Approved by:	Sheet Contents:	Sheet No.
	SUPPLY, DELIVERY AND INSTALLATION OF MODULAR TABLES AT PORT POLICE DIVISION OFFICE PORT OF NASIPIT NASIPIT, AGUSAN DEL NORTE	 MA. GEMMA MAE A. AGUILAR DRAFTSMAN	 AMALIA M. DUMANON CONSTRUCTION FOREMAN A	 VINCENT JUDE A. PORIO SENIOR ENGINEER A / ACTING SUPERVISING ENGINEER A	 ATTY. KAHLIL L. LAMIGO ACTING DIVISION MANAGER A, ASD BELTZASAR L. GELLA ACTING DIVISION MANAGER A, ESD	 MILDRED J. PADILLA PORT MANAGER	PPD GROUND FLOOR PLAN (MODULAR TABLE BUILDING LAYOUT PLAN)	07 07 AUGUST 2021 MGMA

Republic of the Philippines



Government Procurement Policy Board